

heaterSteam - UR

electrical heater humidifier

CAREL



ENG User manual



AVVERTENZE IMPORTANTI

BEFORE INSTALLING OR HANDLING THE APPLIANCE PLEASE CAREFULLY READ AND FOLLOW THE INSTRUCTIONS AND SAFETY STANDARDS DESCRIBED IN THIS MANUAL AND ILLUSTRATED ON THE LABELS ATTACHED TO THE MACHINE.

This humidifier produces non-pressurised steam using heating elements immersed in the water contained in the cylinder (hereafter cylinder); the steam produced is used to humidify environments or industrial processes, through special distributors.

The quality of the water used does not affect the evaporation process, and as a result the appliance can be supplied with untreated water, as long as such water is fit for drinking, demineralised or softened (see Supply water characteristics); the evaporated water is automatically replaced using a refill valve.

To achieve uniform distribution of the heat flow, the heating elements, which are electrically insulated from the water, are covered in an aluminium casting, and are also available with a special non-stick coating to prevent and aid the removal of lime scale.

This appliance has been designed exclusively to directly humidify rooms or ducts, through distributors. It has been developed for this purpose, as long as: the installation, use and maintenance of the unit are carried out according to the instructions contained in this manual and on the labels applied, internally and externally, to the unit.

The environmental conditions and the voltage of the power supply must correspond to those specified. All other uses and modifications made to the device that are not authorised by the manufacturer are considered incorrect.

Liability for injury or damage caused by the incorrect use of the device lies exclusively with the user.

Please note that the machine contains powered electrical devices and hot surfaces.

All service and/or maintenance operations must be performed by specialist and qualified personnel who are aware of the necessary precautions.

Disconnect the machine from the mains power supply before accessing any internal parts.

The local safety standards in force must be applied in all cases.



Disposal of the parts of the humidifier: The humidifier is made up of metallic and plastic parts.

In reference to European Community directive 2002/96/EC issued on 27 January 2003 and the related national legislation, please note that:

1. WEEE cannot be disposed of as municipal waste and such waste must be collected and disposed of separately;
2. the public or private waste collection systems defined by local legislation must be used. In addition, the equipment can be returned to the distributor at the end of its working life when buying new equipment.
3. the equipment may contain hazardous substances: the improper use or incorrect disposal of such may have negative effects on human health and on the environment;
4. the symbol (crossed-out wheeled bin) shown on the product or on the packaging and on the instruction sheet indicates that the equipment has been introduced onto the market after 13 August 2005 and that it must be disposed of separately;
5. in the event of illegal disposal of electrical and electronic waste, the penalties are specified by local waste disposal legislation.

Warranty on materials: 2 years (from the date of production).

Certification: the quality and safety of CAREL products are guaranteed by CAREL's ISO 9001 certified design and production system, as well as CE  or ETL  mark.

1. MODELS	7
1.1 Accessories.....	7
2. DESCRIPTION OF THE MAIN COMPONENTS AND FUNCTIONS	8
2.1 Level control.....	10
2.2 Overfill device.....	10
2.3 Control of steam production.....	10
2.4 Measurement of supply water conductivity- alarm.....	10
2.5 Automatic draining.....	10
2.6 Foam elimination procedure.....	11
2.7 Safety thermostat (Motor Protector)	11
2.8 Autotest procedure.....	11
2.9 Measurement of the water temperature and pre-heating (not available in the version with type C control module)	11
2.10 Dehumidification request signal (not available in the version with type C control module).11	
2.11 Procedure for cleaning the drain valve (UR 2 to 10kg/h/4.4 to 22lbr/h).....	11
3. CONTROL PRINCIPLES	12
3.1 ON/OFF control (control module C).....	12
3.2 Modulating control (control module H).....	12
3.3 Setting the alarm thresholds (type H or T control module).....	13
4. ASSEMBLY	14
4.1 Receipt and storage.....	14
4.2 Dimensions and weights.....	14
4.3 Removing and replacing the front casing.....	14
5. POSITIONING THE UNIT	15
5.1 Fastening.....	15
6. WATER CONNECTIONS	16
6.1 Supply water characteristics	16
6.2 Characteristics of the drain water.....	16
6.3 Technical specifications	17
6.4 Checks.....	17
7. ELECTRICAL CONNECTIONS	18
7.1 Power supply voltages.....	18
7.2 Main control board.....	19
7.3 Description of the terminal block and connections (functions and electrical specifications)...	19
7.4 Auxiliary connections.....	19
7.5 Other auxiliary contacts	21
7.6 Checks.....	21
7.7 Wiring diagrams for the connection of the heating	22
elements.....	22
7.8 Single-phase wiring diagram for 2-4kg/h (4.4-8.8lbr/h) humidifiers with type C control module	23
7.9 Single-phase wiring diagram for 2-4kg/h (4.4-8.8lbr/h) humidifiers with type H or T control module.....	24
7.10 Single-phase wiring diagram for 6kg/h (13.2lbr/h) humidifiers with type C control module.25	
7.11 Single-phase wiring diagram for 6kg/h (13.2lbr/h) humidifiers with type H or T control module	26
7.12 Three-phase wiring diagram for 6-10Kg/h (13.2-22lbr/h) humidifiers with type C control module.....	27
7.13 Three-phase wiring diagram for humidifiers with type H or T control module	28
7.14 Three-phase electrical diagram for 20 (44lbr/h) (208-230-400-460-575V) 27-40Kg/h (59.5-88lbr/h) (400-460-575V) humidifiers with type C control module 400-460-575 V	29
7.15 Three-phase electrical diagram for 20 (44lbr/h) (208-230-400-460-575V) 27-40Kg/h (59.5-88lbr/h) (400-460-575V) humidifiers with type H control module 400-460-575 V.....	30
7.16 Three-phase electrical diagram for 60Kg/h (132.2lbr/h) humidifiers with type C control module 400-575 V.....	31
7.17 Three-phase electrical diagram for 60Kg/h (132.2lbr/h)humidifiers with type H control module 400-575 V	32
7.18 Three-phase electrical diagram for 27Kg/h (59.5lbr/h)humidifiers with type H control module at 208 - 230 V	33

7.19 Three-phase electrical diagram for 27Kg/h (59.5lbr/h) humidifiers with type H control module at 208 - 230 V	34
7.20 Three-phase electrical diagram for 60kg/h (132.2lbr/h) humidifiers with type H control module at 460 V.....	35
7.21 Three-phase electrical diagram for 60kg/h (132.2lbr/h) humidifiers with type C control module at 460 V.....	36
8. STEAM DISTRIBUTION	37
8.1 Ambient steam distribution: ventilated steam distributors.....	37
8.2 Steam distribution in cold rooms.....	37
8.3 Ducted steam distribution: linear and concentrated jet distributors (OEM).....	38
8.4 Concentrated jet steam distribution (OEM) (only for humidifiers up to 10 Kg/h/22 lbr/h)	39
8.5 Positioning linear distributors in the air duct.....	39
8.6 Installation of the steam pipe.....	40
8.7 Installing the condensate return pipe	40
8.8 Checks.....	40
9. START-UP	41
9.1 Preliminary checks.....	41
9.2 Removing the heating element centring spring (only for three-phase models).....	41
9.3 Start-up.....	41
10. THE HUMIDIFIER CONTROLLER	42
10.1 Type C control module, with indication LEDs and ON/OFF action.....	42
10.2 Type H or T control module, numeric LED display, modulating action	43
11. READING AND PROGRAMMING THE PARAMETERS OF THE TYPE H OR T CONTROL MODULE	45
11.1 Reading and programming the set point	45
11.2 Display of SW release.....	45
11.3 Reading and programming the control parameters - reading the measurements	45
11.4 Reading and programming the configuration parameters	46
11.4 Validity of the modifications to the parameters	49
11.5 Recalling the default parameters (factory settings).....	49
11.6 Resetting the hour counter	49
11.7 Displaying and modifying the unit of measure	49
11.8 Automatic total drain for inactivity.....	50
11.9 User-adjustable duration of dilution drain	50
11.10 User-adjustable max. allowed no. of evaporation cycles between 2 dilution drains.....	50
11.11 Reduced fills to restore water level after evaporation	51
11.12 PWM fills after dilution and high-level/foam drains.....	51
12. THE REMOTE CONTROL (OPTIONAL ACCESSORY)	52
12.1 Description of the remote control.....	52
12.2 Programming from the remote control.....	53
12.3 Exiting the programming phase.....	54
13. SHUTTING DOWN THE UNIT	55
14. MAINTENANCE	56
14.1 Maintenance of the cylinder-cylinder.....	56
15. ALARMS AND TROUBLESHOOTING	58
15.1 Alarm summary table.....	58
15.2.....	
Autotest Retry procedure (Fault tolerance)	60
15.3 Troubleshooting	60
16. HUMIDIFIER TECHNICAL SPECIFICATIONS	61
17. SPARE PARTS	62
17a Maintenance of the other plumbing components.....	65
17.2 Replacing the components.....	66
17.3 Spare parts	68
17.4 Disposal of the parts of the humidifier.....	68

1. MODELS

The code designating the model of electric heater humidifier is made up of 10 characters, with the following meaning (Fig. 1a).

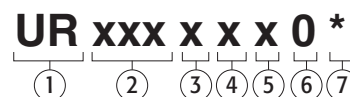

Fig. 1.a

Example: the code UR010CL101 identifies an electric heater humidifier (UR) with:

- rated steam production of 10kg/h (22lbr/h) (010);
- ON/OFF control module (C);
- 400 Vac, three-phase power supply (L);
- full optional version (1).

► **NOTE:** Not all the combinations are possible.

1	ID prefix;		
2	rated instant steam production in kg/h / lbr/h:	mod.	production
		002	2/4.4
		004	4/8.8
		006	6/13.2
		010	10/22
		020	20/44
		027	27/59.5
		040	40/88
		060	60/132.2
3	type of control:	C= ON/OFF H= modulating T= for steam baths;	
4	type - power supply:	type	V
		U= 208	1~N
		D= 230	1~N
		W= 208	3~
		K= 230	3~
		L= 400	3~
		M= 460	3~
		N= 575	3~
5	option:	0= base version 1= full optional version	
6	customisations		
7	S for UR020		

Table 1.a

1.1 Accessories

Table 1.b lists the accessories fitted on the humidifiers, in the various configurations.

	options	type of control					
		C (ON/OFF)		H (modulating)		T (for steam baths)	
		0: base	1: full optional	0: base	1: full optional	0: base	1: full optional
water temperature probe and pre-heater		---	---	incl.	incl.	incl.	incl.
external thermal lining on cylinder		---	incl.	---	incl.	---	incl.
elements coated with non-stick film		---	incl.	---	incl.	---	incl.
lime collection film *		---	incl.	---	incl.	---	incl.
Remote control		---	---	optional	optional	optional	optional
Humivisor		---	---	optional	optional	optional	optional

Table 1.b

- *: not present on the full option version of the 20-27-40-60 kg/h (44-59.5-88-132.2 lbr/h) units;
 ---: not available;
 incl.: accessory included.

2. DESCRIPTION OF THE MAIN COMPONENTS AND FUNCTIONS

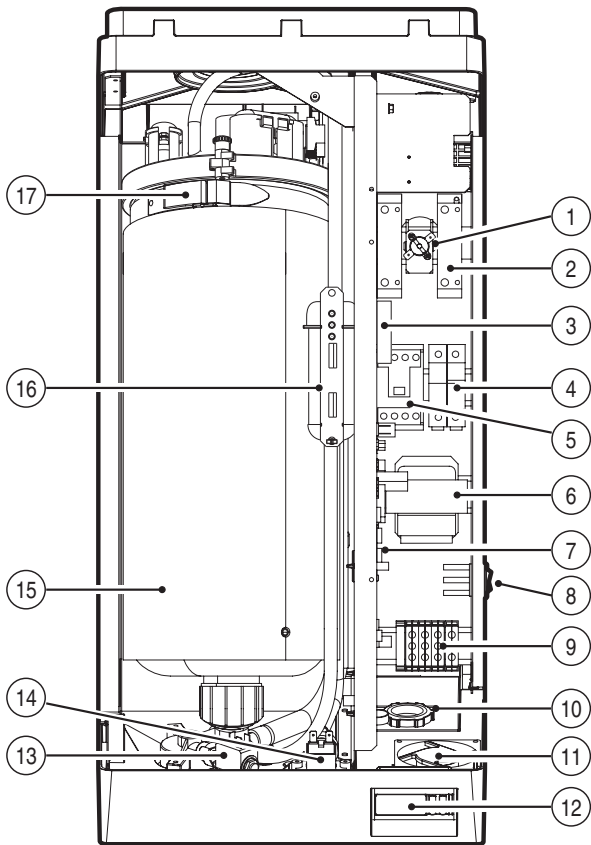

Fig. 2.a

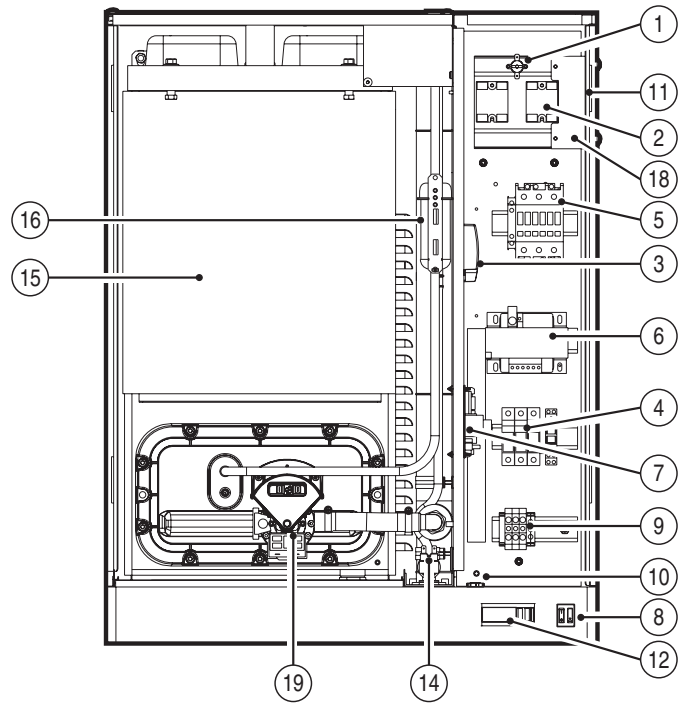

Fig. 2.b

n.	description
1	Klixon (motor overload – in models where featured)
2	Solid state relay (SSR) (in models where featured)
3	Motor protector
4	Fuse carrier base
5	Remote control switch
6	Transformer
7	Relay board
8	ON-OFF and manual drain switch
9	Power cable terminal block
10	Power cable gland
11	Fan (in models where featured)
12	Control module
13	Drain electrovalve
14	Fill electrovalve
15	Cylinder
16	Level controller
17	Locking lever
18	conveyor
19	drain pump

Table 2.a

Humidifiers up to 10 kg/h /22 lbr/h

Humidifiers from to 20-27-40-60 kg/h (44-59.5-88-132.2 lbr/h)

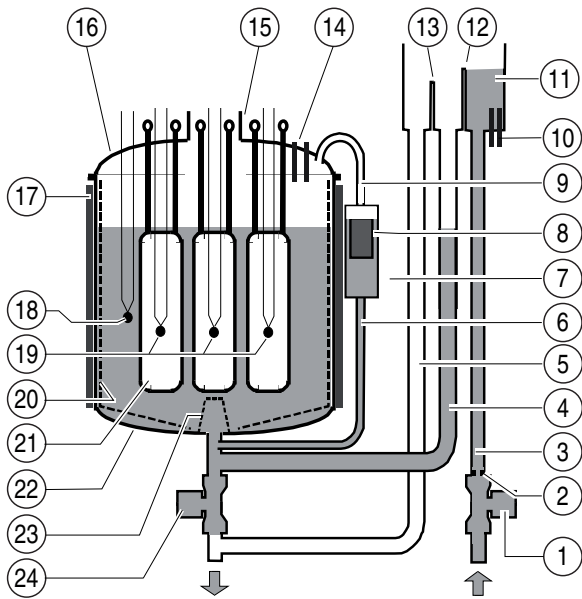

Fig. 2.c

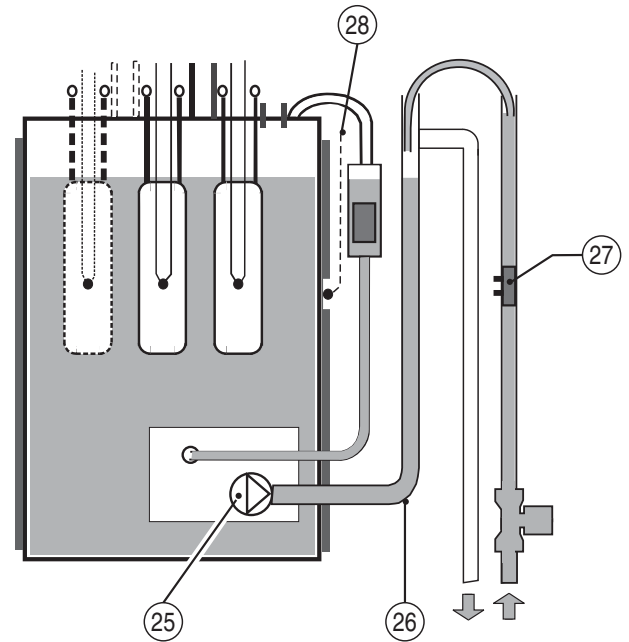

Fig. 2.d

n.	description
1	fill electrovalve
2	flow limiter
3	supply pipe
4	refill pipe
5	overflow pipe
6	connection pipe
7	level gauge housing
8	level control - level switch (following: level switch)
9	equaliser pipe
10	conductivity measurement electrodes
11	fill tank
12	fill diaphragm
13	overflow diaphragm
14	high level electrodes
15	steam outlet pipe
16	cylinder cover
17	thermal lining on the boiler (optional))
18	water temperature sensor (optional)
19	overheating sensors
20	lime collection film
21	heating elements
22	cylinder housing
23	bottom filter
24	drain electrovalve
25	drain pump
26	Drain column
27	Conductivity meter
28	water temperature sensor (optional)

Table 2.b

2.1 Level control

Steam is produced with the heating elements completely immersed in water, whose level is controlled by a sensor made up of two independent and overlapping float switches, that is, the working level switch and safety level switch.

2.1.1 Level control

It is composed of a float contained in a plastic pipe. Constrained to the level control case, an electronic board detects the float position and displays the levels through three LEDs: green working level, yellow charge level, red safety level. The signals, working and safety level, are detailed in the paragraphs 2.1.2, 2.1.3.

2.1.2 Working level switch

This switch, which activates the fill electrovalve, introduces water through the special pipe into the fill tank, from where, dropping from a fill diaphragm, it refills the level inside the cylinder; the fill electrovalve is fitted with a flow limiter, maintaining the flow basically constant on changes in mains pressure.

2.1.3 Safety level switch

This switch shuts off power to the elements, activating the alarm in the case where the level is insufficient.

2.2 Overfill device

This is a device used to avoid water exiting the cylinder over the safety level, due for example to the malfunctioning of the control module (for more details, see THE HUMIDIFIER CONTROLLER) or to leaking from the fill electrovalve.

The fill tank is fitted with an overfill diaphragm which diverts the excess inlet water, discharging it through special pipe.

The overfill diaphragm is lower than the fill diaphragm to avoid back flow through the supply pipe.

2.3 Control of steam production

Steam production can be controlled either:

- By step, alternating steam production with standby using a humidistat or external contact; steam production can be controlled in four steps with pseudo-modulation from 30% to 100% of rated power, cyclically activating the remote-control switch (humidifier with type C control module).
- By continuous modulation from 0% to 100% of rated power, using solid-state relays (SSR); the control logic is PWM (pulse width modulation) with programmable base times (humidifier with type H or T control module).

2.4 Measurement of supply water conductivity- alarm

To optimise the functionality of the humidifier by suitably portioning the automatic draining cycles (see Automatic draining), when the fill electrovalve is opened the conductivity of the inlet water is measured using the special electrodes in the tank.

Two high conductivity thresholds can be set to activate respectively a pre-alarm and an alarm (with the shut-down of the appliance) when these thresholds are exceeded for at least 60 minutes, or instantly if the value measured is greater than three times the set value.

2.5 Automatic draining

The automatic draining function is managed by the control module. Part of the water contained in the cylinder is drained automatically, being replaced by fresh water to prevent an excessive salt concentration following the evaporation process.

The drain pump/electrovalve is operated for a pre-set time at intervals that vary automatically as a function of the steam production and the content of solids dissolved in the supply water, detected using the conductivity measuring electrodes.

Irrespective of the concentration of salt in the supply water, at least one drain cycle is performed within a maximum interval based on the quantity of steam produced; this is also true for demineralised supply water.

2.6 Foam elimination procedure

The level of water inside the cylinder is maintained by the level control at around 10-12 cm / 3.94-4.72inch (about 18-20 cm / 7.1-7.87inch for the cylinder of the 20-60 kg/h/44-132.2lbr/h humidifiers) from the top of the cylinder, therefore, when the high level electrodes are wet, an anomalous situation arises, generally caused by the presence of foam. In this case a drain procedure is activated, and is repeated until the phenomenon desists or, in the event of multiple activation, until the appliance is shut-down and an alarm state is signalled.

2.7 Safety thermostat (Motor Protector)

The mechanical safety thermostat with manual reset intervenes in the event of overheating, caused by a lack of water inside the cylinder due to the malfunctioning of the minimum level control. This deactivates the relay that controls the power supplied to the elements, and places the humidifier in an alarm state.

2.8 Autotest procedure

Each time the humidifier is started (switched from the OFF to the ON position), an autotest (default) procedure is performed, including checks on the operation of the level control, to test the regular functioning of the appliance:

1. "At" is shown during the autotest;
2. The autotest can be temporarily manually disabled by pressing key SEL during the initial 5 seconds after switching on heaterSteam: "-nt" will be shown. Note that this procedure disables the autotest only for the switch-on in course, not permanently (read below for disabling the autotest permanently);
3. The autotest can be disabled permanently by setting the parameter b1 as shown in table in chapter 11.4.

On start-up and on each draining cycle the operation of the level control is automatically checked by opening the fill electrovalve until the activation of the working level switch (green LED) and, successively, opening the drain pump electrovalve until the activation of both level switches, and finally, restoring the correct level, NOTE: returns to the working level only if there is demand, otherwise remains at the safety level; in the event of a failed test or irregular timing the remote-control switch is automatically deactivated and the alarm activated.

2.9 Measurement of the water temperature and pre-heating (not available in the version with type C control module)

The control module measures, using an NTC sensor, the temperature of the water, and can be programmed to activate the pre-heating function near the value set for the start of humidification; in this way, steam production occurs more quickly.

2.10 Dehumidification request signal (not available in the version with type C control module)

If activated, this function closes the relay contact when the relative humidity measured by the transducer connected to the control module exceeds the set threshold.

This signal can be used to activate an external dehumidification device.

2.11 Procedure for cleaning the drain valve (UR 2 to 10kg/h/4.4 to 22lbr/h)

For the models with drain valve there are two procedures used to clean the drain valve.

The purpose is:

1. to prevent the valve from being blocked due to flakes of lime scale.
 2. to prevent the solenoid drain valve from leaking.
- The first procedure is activated during a drain to dilute (automatic draining, see par. 2.5), drain due to foam or due to inactivity cycle. This procedure is used to repeatedly activate and deactivate (with the fill valve open) the drain valve for 1 second at start of the drain cycles.
 - The second procedure, called "chattering", is activated when filling the water in steady operation, and involves repeatedly activating and deactivating the drain valve for 1 second when the algorithm calculates that a no water alarm condition ("EF") is about to occur.

3. CONTROL PRINCIPLES

The range of humidifiers includes the following control possibilities.

3.1 ON/OFF control (control module C)

The action in this case is all or nothing, activated by an external contact that determines the set point and the control differential (or hysteresis).

Average steam production can be adjusted using a pseudo-modulating action, through the cyclical activation of the remote-control switch with a fractional actuation period (operation) that can be programmed in four steps: 30%, 50%, 75% or 100% of the total time (this mode can not be applied in severe operating conditions and without consequences on the noise level, caused by the frequent activation of the remote-control switch).

3.2 Modulating control (control module H)

The appliance is fitted with solid-state relays and steam production can be controlled continuously as a function of the required quantity, in one of the following modes.

3.2.1 ON/OFF control (parameter A0=0)

As for the type C control module (see ON/OFF control (type C control module)).

3.2.2 Slave control, with signal emitted from an external regulator (parameter A0=1)

Steam production is proportional to the value of an external signal Y, (selected by programming one of the following standards: 0 to 1Vdc; 0 to 10Vdc; 2 to 10Vdc; 0 to 20mA; 4 to 20mA) the entire range of which is indicated by BP (proportional band).

The maximum production Pmax, corresponding to the maximum value of the external signal Y, can be programmed between 10% and 100% of the rated value of the humidifier.

The minimum production Pmin is fixed at 10% of the rated value, with an activation hysteresis provided by the value hy, equal to 2% of the entire range BP of the external signal Y. If enabled, the pre-heating function overlaps the control diagram, and is activated when the external signal Y is lower than the activation point for steam production by a quantity b2.

Key

1	steam production;
2	pre-heating;
3	activated
4	deactivated

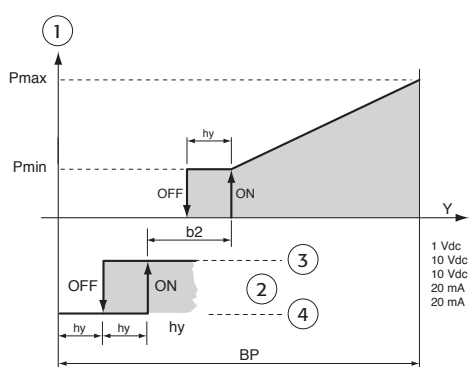

Fig. 3.a

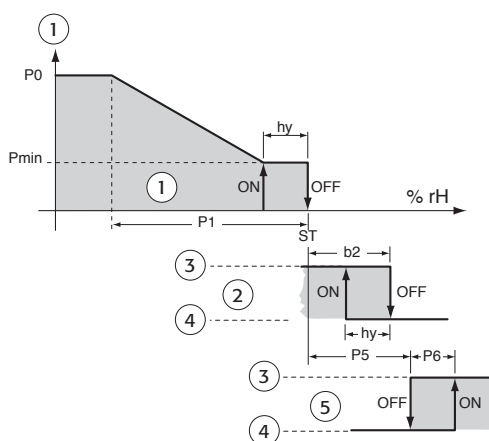

Fig. 3.b

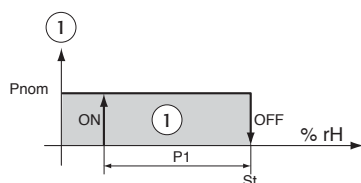

Fig. 3.c

3.2.3 Autonomous control with relative humidity transducer (parameter A0=2)

Steam production is linked to the measurement of % rH, performed by the relative humidity transducer connected to the regulator, and increases as the distance from the set point St increases.

The maximum production P0, which occurs when the relative humidity is less than the set point by a value P1, can be programmed between 10% and 100% of the rated value of the humidifier.

The minimum production Pmin is fixed at 10% of the rated value, with an activation hysteresis provided by the value hy, equal to 10% of P1.

The pre-heating function, if enabled, overlaps the control diagram and is activated when the relative humidity % rH, measured by the transducer, is higher than St by a programmable quantity b2.

The dehumidification function, if enabled, overlaps the control diagram and is activated when the relative humidity % rH, transmitted by the transducer, is higher than St by a programmable quantity P5+P6; the hysteresis of the step, also programmable, is equal to P6.

To check that the relative humidity measured by the transducer is within the pre-set values, the control module with autonomous control allows two alarm thresholds to be programmed:

- high relative humidity alarm threshold P2;
- low relative humidity alarm threshold P3.

When these thresholds are exceeded, after a programmable delay P4, an alarm state is activated, with the closing of the contact of the corresponding relay on the main control board.

With autonomous control (parameter A0=2) it is also possible to have an ON/OFF action, as represented in the graph, by disabling power modulation (setting parameter b0=0).

The pre-heating and/or dehumidification, if enabled, remain unchanged.

Key

1	steam production;
2	pre-heating;
3	activated
4	deactivated
5	dehumidification

3.2.4 Autonomous control with ambient relative humidity transducer and outlet humidity limiting transducer (parameter A0=3)

In this case too the regulator modulates steam production as a function of the measurement % rH performed by the main relative humidity transducer, however, in addition, its entity is limited if the relative humidity % rH2 measured by a second compensation transducer placed in the air duct downstream from the humidifier exceeds the maximum desired value.

To prevent the relative humidity measured by the transducer in the air duct downstream from the humidifier exceeding a value considered as excessive, the control module with autonomous control and second transducer connected allows a high outlet relative humidity alarm threshold P9, to be programmed. If this threshold is exceeded, after a programmable delay P4, an alarm state is activated, with closing of the contact of the corresponding relay on the main control board.

Key

1	production limit %
2	steam production
3	limit probe (% rH2)

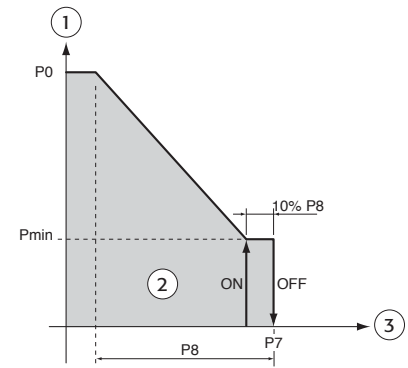

Fig. 3.d

3.2.5 Application for steam baths (type T control module)

In applications for steam baths, where the control probe measures temperature rather than humidity, the same considerations are valid as for the type H control module with modulating action and autonomous control.

Recommended transducer: SSTOOB/P40, ASET030001 or ASET030000.

3.3 Setting the alarm thresholds (type H or T control module)

The control module panel allows the setting of limit thresholds for the activation of the alarm in the event where these are exceeded.

These alarm thresholds can be programmed using the following control parameters:

- **P2**: high relative humidity alarm threshold, measured by the room probe;
- **P3**: low relative humidity alarm threshold, measured by the room probe;
- **P4**: alarm signalling delay (to prevent false signals);
- **P9**: high relative humidity alarm threshold, measured by the outlet probe (for ducted humidification).

Parameters P2, P3, P4 are programmable only when A0=2 or 3; parameter P9 is programmable only when A0=3.

Furthermore, the control module can signal the excessive conductivity (and salt concentration) of the supply water, but only as a default setting.

WARNING: the parameter A0 and the operating and alarm parameters Px and b0 are set in the factory (default values valid for normal applications). Nonetheless, these can be modified by the user, following the instructions contained in: **Reading and programming the parameters for the type H or T control module.**

4. ASSEMBLY

4.1 Receipt and storage

Check that the humidifier is intact upon receipt and immediately notify the shipping agent, in writing, of any damage that may be due to improper or careless transport. Move the humidifier to the place of installation before removing it from the packaging, grasping the neck only from below the base. Open and remove the box, remove the layer of protective material and move the humidifier from the pallet to the support surface, keeping it vertical at all times; only remove the protective bag when installing the unit.

4.2 Dimensions and weights

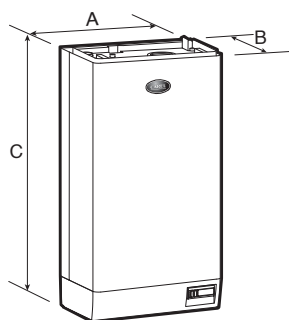

Fig. 4.a

		models							
		UR002	UR004	UR006	UR010	UR020	UR027	UR040	UR060
dimensions (mm) / (inch)	A	365 / 14.37	365 / 14.37	365 / 14.37	365 / 14.37	690 / 27.17	690 / 27.17	690 / 27.17	876 / 34.49
	B	275 / 10.83	275 / 10.83	275 / 10.83	275 / 10.83	438 / 17.24	438 / 17.24	438 / 17.24	438 / 17.24
	C	620 / 24.41	620 / 24.41	710 / 27.95	710 / 27.95	887 / 34.92	887 / 34.92	887 / 34.92	887 / 34.92
weights (kg)/ (libre)	packaged	26 / 57.2	26 / 57.2	31 / 68.2	31 / 68.2	73 / 160.6	73 / 160.6	77 / 169.4	98 / 215.6
	empty	21 / 46.2	21 / 46.2	26 / 57.2	26 / 57.2	63 / 138.6	63 / 138.6	67 / 147.4	87 / 191.4
	installed *	27 / 59.4	27 / 59.4	35 / 77	35 / 77	97 / 213.4	97 / 213.4	114 / 250.8	155 / 341

Table 4.a

*: in operating conditions, filled with water

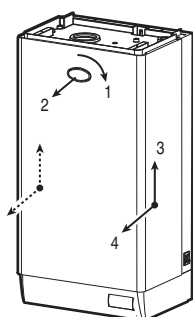

Fig. 4.b

4.3 Removing and replacing the front casing

To remove the front casing of the humidifier, proceed as follows:

1. turn the oval badge with the CAREL logo 90°, until the ground screw below can be seen;
2. remove the screw, using a screwdriver;
3. grip the casing by the sides and lift it around 2 centimetres, releasing the contours from the raised edges on the cover and the base of the structure;
4. remove the casing by pulling it forward.

To close the appliance, proceed as follows:

1. turn the red oval plate with the CAREL logo so that the fastening hole below is visible;
2. slide the casing onto the structure, keeping it in a slightly raised position, until it rests on the edges of the rear piece; then move it downwards slotting the upper and lower contours into the edges of the cover and the base of the structure respectively; check that the fastening hole below the logo is in line with the threaded bush attached to the structure;
3. fasten the ground screw using a screwdriver;
4. place (rotate) the oval plate with the CAREL logo in the closed position.

For 20-60 kg/h/44.1 - 132.2 lbr/h humidifiers

To remove the front casing, proceed as follows:

1. turn the oval badge with the CAREL logo 90°, until the ground screw below can be seen;
2. remove the screw, using a screwdriver;
3. grip the casing by the sides using the handles, and lift it so that the hooks on the sides are released from the structure;
4. remove the casing by pulling it forward.

To close the appliance, proceed as follows:

1. turn the red oval plate with the CAREL logo so that the fastening hole below is visible;
 2. slide the casing onto the structure, keeping it in a slightly raised position, until the hooks fit into the structure; check that the fastening hole below the logo is in line with the threaded bush attached to the structure;
 3. fasten the ground screw using a screwdriver;
- place (rotate) the oval plate with the CAREL logo in the closed position.

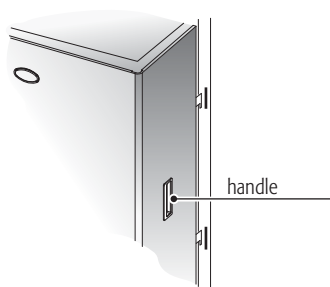

Fig. 4.c

5. POSITIONING THE UNIT

! The humidifier must be positioned and fastened by qualified personnel, following the instructions listed herein.

Choose the best location for the installation of the steam distributor, that is the position which minimises the length of the steam pipe or, in the case of direct ambient humidification using a ventilated distributor, the central point of the space being humidified (see STEAM DISTRIBUTION). The unit is designed to be mounted to a wall that must be able to support its weight in operating conditions (see Dimensions and weights).

The metal casing of the humidifier heats up during operation, and the rear part resting against the wall may reach temperatures above 60 °C / 140 °F; ensure that this does not cause any problems. Make sure the machine is level, respecting the minimum distances indicated in the drawing, to allow the necessary maintenance operations.

! **WARNING:** ensure that the cooling fan outlet grille is not blocked or covered.

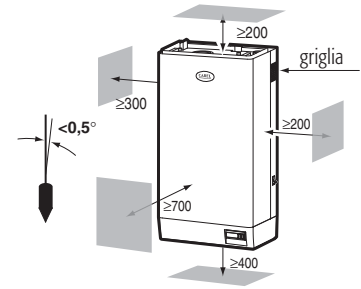

Fig. 5.a

5.1 Fastening

The appliance must be fastened to the wall using the supplied screws and plugs. Use the following distances for the drilling template.

	models			
	UR002 UR004	UR006 UR010	UR020-UR027	UR060 UR040
X (mm) / (inch)	220 / 8.66	220 / 8.66	495 / 19.48	681 / 26.81
Y (mm) / (inch)	500 / 19.68	590 / 23.23	740 / 29.13	740 / 29.13
Z (mm) / (inch)	-	-	155 / 6.10	248 / 9.76
Z' (mm) / (inch)	-	-	155 / 6.10	248 / 9.76

Table 5.a

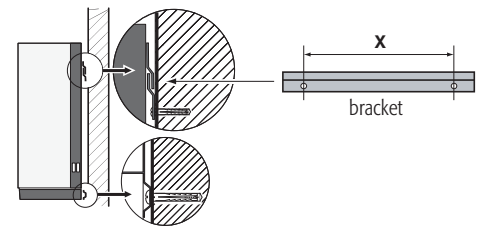

Fig. 5.b

Fasten the bracket supplied with the humidifier to the wall, **checking that it is horizontal using a spirit level**; if it is mounted to a brick wall, the plastic wall plugs (\varnothing 8 mm)/(\varnothing 0.31 inch) and screws (\varnothing 5 mm x L= 50 mm)/(\varnothing 0.2 inch x L=1.97 mm) supplied can be used.

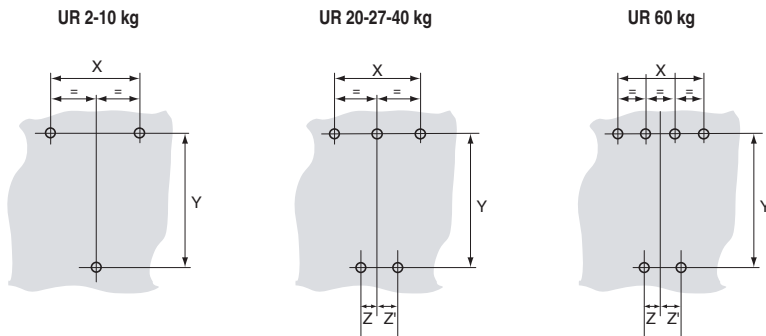

Fig. 5.c

Hang the appliance on the bracket using the contour on the upper edge of the rear of the unit. Finally, fasten the appliance to the wall using the hole in the centre rear of the base. This can be easily reached from the bottom.

6. WATER CONNECTIONS



The water connections for the supply and the draining of the unit must be made by specialist and qualified personnel, who are capable of performing the work correctly and according to local standards. Before making the connections, ensure that the machine is disconnected from the mains power.

6.1 Supply water characteristics

The supply water for the electric heater humidifier must not be corrosive, must not emit bad odours, and must not contain too much lime to avoid excessive deposits.

The water, supplied from mains **drinking** water or **demineralised** water, must have the following characteristics:

LIMIT VALUES FOR THE HUMIDIFIERS SUPPLY WATER TO HEATING ELEMENTS

				Not covered heating elements		Heating elements covered by the antiadherent film	
				min.	max.	min.	max.
Specific conductivity at 20°C /68°FH	σ_{20}	-	$\mu\text{S}/\text{cm}$	20	1500	1	1500
Total dissolved solids	TDS	-	mg/l	(1)	(1)	(1)	(1)
Fixed residual at 180°C/ 356°FH	R ₁₈₀	-	mg/l	(1)	(1)	(1)	(1)
Hydrogenion activity	6.1.1 pH	-		6,5	8	6	8.5
Total hardness	TH	-	mg/l CaCO ₃	0 (2)	400	0	400
Temporary hardness		-	mg/l CaCO ₃	0 (3)	30	0	300
Chloride		-	ppm Cl	=	20	=	50 (4)
Iron + Manganese		-	mg/l Fe+Mn	=	0.2	=	0.2
Silica		-	mg/l SiO ₂	=	20	=	20
Residual Chlorine		-	mg/l Cl -	=	0.2	=	0.2
Calcium sulphate		-	mg/l CaSO ₄	=	100	=	100
Metallic impurities		-	mg/l	0	0	0	0
Solvents, diluents, detergents, lubricants		-	mg/l	0	0	0	0

Table 6.a

(1) Values depending on the specific conductivity; in general: TDS @ 0,93 * σ_{20} ; R₁₈₀ @ 0,65 * σ_{20} ;

(2) Not lower than 200% the content of chloride in mg/l Cl-

(3) Not lower than 300% the content of chloride in mg/l Cl-

(4) It could be necessary to intervene on the drain rate to avoid a concentration in the water higher than 300 mg/l Cl-.

Note that treating the water with softeners or polyphosphates does not decrease the quantity of dissolved salts, and can lead to the formation of foam and hence irregular operation and corrosion of heating elements.

If softened water is used, it should be diluted with mains tap water in such proportions as to ensure a minimum hardness of 5° fH, and parameter b4 should be set (value 1500) so as to increase the frequency of the drain cycles for dilution.

Not recommended:

- the use of well water, industrial water or water from cooling circuits and, in general, water which may be chemically or bacteriologically contaminated;
-  the addition to the water of disinfectants or anticorrosion compounds, as these may cause irritation.

Nota: no relationship can be proven between water hardness and conductivity; nonetheless, as an indication only, water with a hardness of 40°fH should have an approximate conductivity of around 900-1000 mS/cm at 20 °C/68°FH.

6.2 Characteristics of the drain water

Inside the humidifier water boils and steam is produced, without the addition of any kind of substance. The drain water, therefore, contains the same substances as those dissolved in the supply water, yet in a greater proportion, depending on the concentration in the supply water and the set drain cycles; it can also reach a temperature of 100 °C/212°FH. Not being toxic, it can be drained into the backwater collection system. The drain pipe, as well as being resistant to high temperatures, must also guarantee the correct downflow of the water; a downward slope of at least 5° is therefore recommended.

6.3 Technical specifications

The installation of the humidifier requires connection to the supply water and drain pipe.

The connection of the supply water can be made using rigid or flexible pipes with a minimum recommended internal diameter of 6mm, fitted with a shut-off tap to allow the appliance to be disconnected during maintenance operations. To simplify installation it is recommended to use CAREL flexible pipes with an internal diameter of 6 mm and an external diameter of 8mm (code 1312350APN) and the rotating 3/4" G straight (code 9995727ACA) or elbow connector (code 9995728ACA), available upon request.

It is recommended to install a mechanical filter to trap any solid impurities.

The drain water connection is made using a section of rubber or plastic pipe resistant to temperatures of 100°C/212°F, with a recommended internal diameter of 36 mm/1.42inch (see table 6.3.1).

This section of pipe must be fastened using metal clamps:

- above, onto the appliance outlet pipe coupling;
- below, onto the rigid pipe, with a minimum slope of 5°.

In the humidifiers UR 020-027-040-060 the drain tank must be emptied connecting a rubber pipe, which has to be connected to the discharge system, withstanding 100 °C/212°F with $\varnothing_{int.} = 20 \text{ mm} / 0.79 \text{ inch}$ and fastened with a metallic band.

Key:

1	power supply pipe fitting
2	drain pipe fitting
3	pipe fitting for drain tank emptying

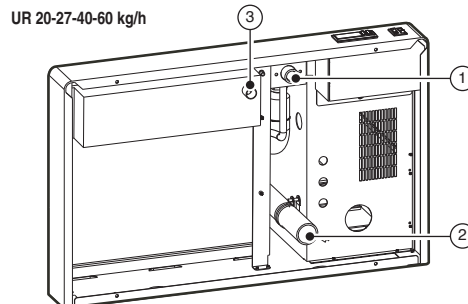
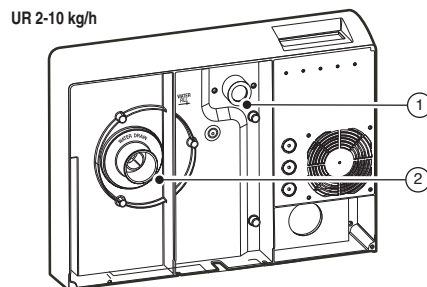

Fig. 6.a

6.3.1 Table of technical specifications

technical specifications	models							
	UR002	UR004	UR006	UR010	UR020	UR027	UR040	UR060
maximum instant flow rate for supply water (l/min.) / (gpm)	0,6/0.13	0,6/0.13	1,2/0.26	1,2/0.26	4/0.88	4/0.88	4/0.88	10/2.2
supply water connection	G ^{3/4} "M	G ^{3/4} "M	G ^{3/4} "M	G ^{3/4} "M	G ^{3/4} "M	G ^{3/4} "M	G ^{3/4} "M	G ^{3/4} "M
minimum recommended supply pipe internal diameter (mm) / (inch)	6/0.24	6/0.24	6/0.24	6/0.24	6/0.24	6/0.24	6/0.24	6/0.24
maximum instantaneous flow rate for drain water (l/min.) / (gpm)	5/1.09	5/1.09	5/1.09	5/1.09	22,5/4.95	22,5/4.95	22,5/4.95	22,5/4.95
drain water connection external diameter (mm) / (inch)	40/1.57	40/1.57	40/1.57	40/1.57	40/1.57	40/1.57	40/1.57	40/1.57
recommended drain pipe internal diameter (mm) / (inch) *	36/1.42	36/1.42	36/1.42	36/1.42	36/1.42	36/1.42	36/1.42	36/1.42

Table 6.b

* to allow the water downflow do not connect using lower diameters.

6.3.2 Diagram of water connections

Key:

1	drain
2	water supply
3	tap
4	filter

IMPORTANT WARNING: the drain pipe must be free, without back-pressure and with a drain trap immediately downstream from the connection to the humidifier. We suggest you use a safety device (not supplied) that, in case of breaking of the hydraulic connections outside the humidifier, prevents possible flooding.

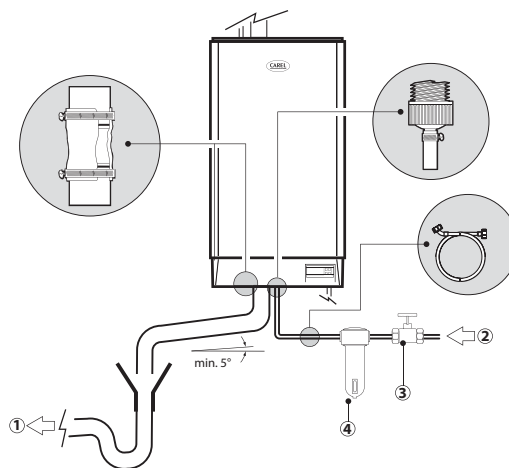

Fig. 6.b

6.4 Checks

The following conditions represent correct water connections:

- disconnection of the supply water line using a shut-off tap;
- presence of a mechanical filter in the supply water line;
- water temperature and pressure within the acceptable values;
- drain pipe resistant to temperatures of 100°C/212°F;
- minimum drain pipe internal diameter of 40mm/1.57 inch;
- minimum slope of drain pipe greater than or equal to 5°.

IMPORTANT WARNING: on completion of the installation procedure, flush the supply pipe for around 30 minutes by passing water directly through the pipe and without introducing it into the humidifier. This will allow the elimination of any scoria and processing residues that may cause the formation of foam during the boiling process.

7. ELECTRICAL CONNECTIONS



The electrical connections must be made by specialist and qualified personnel, who are capable of performing the work correctly and according to local standards. Before making the connections, ensure that the machine is disconnected from the mains power.

Check that the voltage of the appliance's power supply corresponds to the value indicated on the data plate inside the electrical panel. Introduce the power and ground connection cable gland into the electrical panel through the fairlead supplied, connect the ends to the terminals and fasten them in place using the special tear-proof cable gland clamp (see Fig. 2.1). The power line to the humidifier must be fitted with a cut-off switch and fuses protecting against short-circuits, to be mounted by the installer. Table 7.1.1 shows the recommended cross-sections of the power cable and the recommended sizes of the fuses; note, however, that this data is purely indicative and, in the event of non-conformity with local standards, the latter must prevail.

7.1 Power supply voltages

Table 7.a lists the electrical data regarding the power supply voltages of the various models and the functional characteristics of each. Note that some models may be powered at different voltages, obviously with different consumption and steam production values.

base model	power supply		nominal characteristics								
	code	voltage ⁽¹⁾ (V - type)	elements ⁽²⁾ (no x W)	connection type ⁽³⁾	current (A) ⁽²⁾	power (kW) ⁽²⁾	production (kg/h) / (lbs/ hr) ^{(2) (5)}	cable section ⁽⁴⁾ (mm ²) / (AWG)	line fuses ⁽⁴⁾ (A / tipo)	electrical dia- gram (Fig.)	wiring diagram of the heater connec- tion (Fig.)
UR002	U	208 - 1~N	1 x 29,5	-	7	1,5	2 / 4.4	2,5/14	10 / rapid	7.p.b and 7.p.c	7.o.d
	D	230 - 1~N	1 x 29,5	-	7,8	1,8	2,4 / 5.29	2,5/14	10 / rapid		
UR004	U	208 - 1~N	1 x 17,6	-	11,8	2,5	3,3 / 7.27	2,5/14	16 / rapid	7.p.d and 7.p.e	7.o.c
	D	230 - 1~N	1 x 17,6	-	13	3	4 / 8.8	2,5/14	16 / rapid		
UR006	U	208 - 1~	3 x 28,1	≡	22,2	4,6	6,2 / 13.6	6/10	32 / rapid	7.p.f and 7.p.g	7.o.b
	D	230 - 1~	3 x 35,3	≡	19,6	4,5	6 / 13.2	6/10	25 / rapid		
	W	208 - 3~	3 x 28,1	Δ	3 x 12,8	4,6	6,2 / 13.6	2,5/14	16 / rapid		
	K	230 - 3~	3 x 35,3	Δ	3 x 11,3	4,5	6,0 / 13.2	2,5/14	16 / rapid		
	L	400 - 3~	3 x 35,3	Y	3 x 6,5	4,5	6,0 / 13.2	2,5/14	10 / rapid		
	M	460 - 3~	3 x 47,0	Y	3 x 5,7	4,5	6,0 / 13.2	2,5/14	10 / rapid		
UR010	N	575 - 3~	3 x 73,5	Y	3 x 4,5	4,5	6,0 / 13.2	2,5/14	10 / rapid	7.p.h and 7.p.i	7.o.a
	W	208 - 3~	3 x 17,3	Δ	3 x 20,8	7,5	10,0 / 22.04	6/10	25 / rapid		
	K	230 - 3~	3 x 21,3	Δ	3 x 18,8	7,5	10,0 / 22.04	6/10	25 / rapid		
	L	400 - 3~	3 x 21,3	Y	3 x 10,9	7,5	10,0 / 22.04	2,5/14	16 / rapid		
	M	460 - 3~	3 x 28,1	Y	3 x 9,4	7,5	10,0 / 22.04	2,5/14	16 / rapid		
UR020	N	575 - 3~	3 x 44,0	Y	3 x 7,5	7,5	10,0 / 22.04	2,5/14	16 / rapid	7.p.j e 7.p.k	7.o.a
	W	208 - 3~	6 x 16	2 Δ	3 x 45,1	16,2	21,6 / 47.6	16/6	50 / rapid		
	K	230 - 3~	6 x 21,5	2 Δ	3 x 37,1	14,7	19,7 / 43.4	16/6	50 / rapid		
	L	400 - 3~	6 x 21,5	Y	3 x 21,3	14,7	19,7 / 43.4	6/10	25 / rapid		
	M	460 - 3~	6 x 27	Y	3 x 19,7	115,7	21 / 46.3	4/12	20 / rapid		
UR027	N	575 - 3~	6 x 47	Y	3 x 14,8	114,6	19,6 / 43.2	4/12	20 / rapid	7.p.l e 7.p.m	7.o.b
	W	208 - 3~	6 x 12,0	2 Δ	3 x 60,0	21,6	28,8 / 63.5	25/14	80 / rapid		
	K	230 - 3~	6 x 16,0	2 Δ	3 x 49,8	19,8	26,4 / 58.2	16/6	60 / rapid		
	L	400 - 3~	6 x 16,0	Y	3 x 28,6	19,8	26,4 / 58.2	10/8	50 / rapid		
	M	460 - 3~	6 x 21,5	Y	3 x 24,7	19,7	26,3 / 57.9	6/10	32 / rapid		
UR040	N	575 - 3~	6 x 34,0	Y	3 x 19,5	19,4	26,0 / 57.3	6/10	25 / rapid	7.p.n e 7.p.o	7.o.f
	L	400 - 3~	6 x 10,5	Y	3 x 43,6	30,2	40,3 / 88.8	16/6	60 / rapid		
	M	460 - 3~	6 x 14,0	Y	3 x 38,1	30,3	40,4 / 89	16/6	60 / rapid		
UR060	N	575 - 3~	6 x 22,0	Y	3 x 30,2	30,0	40,1 / 88.4	10/8	50 / rapid	7.p.p e 7.p.q	7.o.g
	L	400 - 3~	9 x 10,5	Y	3 x 65,4	45,3	60,5 / 133.4	25/14	80 / rapid		
	M	460 - 3~	9 x 14,0	Y	3 x 57,1	45,5	60,6 / 133.6	25/14	80 / rapid		
UR060	N	575 - 3~	9 x 22,0	Y	3 x 45,3	45,1	60,1 / 132.5	16/6	50 / rapid	7.p.r e 7.p.s	7.o.h

Tab. 7.a

- ⁽¹⁾ Tolerance allowed on rated mains voltage: ± 10%.
- ⁽²⁾ Tolerance on rated values: +5%, -10% (EN 60335-1).
- ⁽³⁾ -: single-phase; ≡: single-phase in parallel; Δ: delta; Y: star.
- ⁽⁴⁾ Recommended values; referred to the laying of the cable in closed PVC or rubber raceways with a length of 20 m; the standards in force must in any case be followed.
- ⁽⁵⁾ Instant steam production: the average steam production may be influenced by external factors, such as: ambient temperature, water quality, steam distribution system.

7.2 Main control board

The auxiliary connections, depending on the chosen model and the control module, must be made by introducing the external cables into the electrical panel. For this purpose use the smaller fairlead on the base of the machine, passing the cables through the raceway on the internal partition to the removable screw terminals placed on the main control board, as shown in Fig. 7.a and described in the following paragraph.

Key:

1.	terminal block G (dehumidification contact)
2.	terminal block H (alarm contact)
3.	remote manual DRAIN command terminal block K
4.	terminal block I (control signals)
5.	terminal block J (to remote terminal or supervisory system)

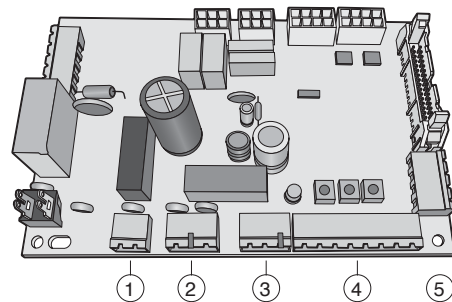

Fig. 7.a

7.3 Description of the terminal block and connections (functions and electrical specifications)

 Before connecting the probes or the external regulator, set parameters A2 and A6 according to the control signal (see THE HUMIDIFIER CONTROLLER).

terminal	function	electrical characteristics
1I	outlet probe signal input	input impedance: 50 Ω if programmed for 0 to 20 mA or 4 to 20 mA 60 kΩ if programmed for 0 to 1 V or 0 to 10 V or 2 to 10 V
2I	GND	
3I	≈ 32 Vdc	derived from rectifying of 24 Vac; max 250 mA
4I	12 Vdc stabilised	accuracy ± 5%; I _{max} =50 mA
5I	room probe signal input or signal from external regulator	input impedance: 50 Ω if programmed for 0 to 20 mA or 4 to 20 mA 60 kΩ if programmed for 0 to 1V or 0 to 10V or 2 to 10 V
6I	GND	
7I	remote enabling	R _{max} =50 Ω; V _{max} =24 Vdc; I _{max} =10 mAdc
8I		
1H	NO alarm contact	250 V; 8A with resistive load; 2A with indicative load
2H	common alarm contact	
3H	NC alarm contact	
1G	NO dehumidification contact	250 V; 8A with resistive load; 2A with indicative load
2G	common dehumidification contact	
1J	≈ 32 Vdc	derived from rectifying of 24 Vac; max 250 mA
2J	L +	standard RS485
3J	L -	
4J	GND	
1K	remote control terminal block button switch for DRAIN command with simultaneous disconnection of the power supply	NC contact
2K		common contact
3K		NO contact

Tab. 7.b

7.4 Auxiliary connections

Before making the auxiliary connections, disconnect electrical power to the appliance!

7.4.1 Type C control module with ON/OFF action

The humidifier is controlled by a mechanical humidistat H or a voltage-free remote contact CR, or a combination of both.

The control module can be connected to an RS485 serial line, or alternatively to the CAREL Humivisor remote control panel, marked as MT, or to a remote supervisor.

The diagrams in Fig. 7.b and 7.c show the connections to be made on the terminal block I, in the following cases:

- action commanded by simple enabling contact;
- action from external mechanical humidistat;
- combination of the above.

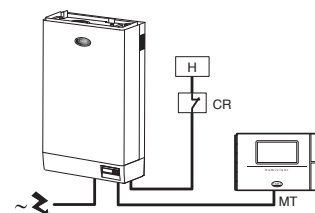

Fig. 7.b

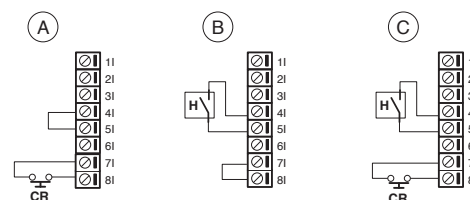

Fig. 7.c

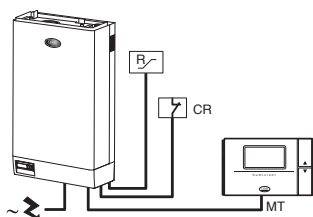

Fig. 7.d

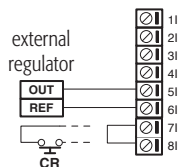

Fig. 7.e

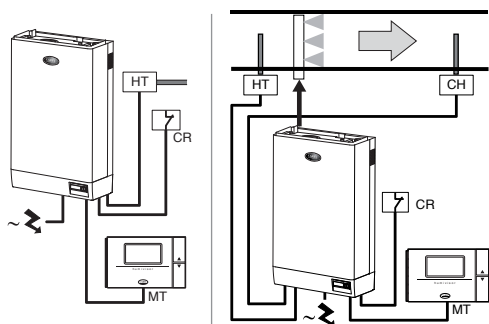

Fig. 7.f

Fig. 7.g

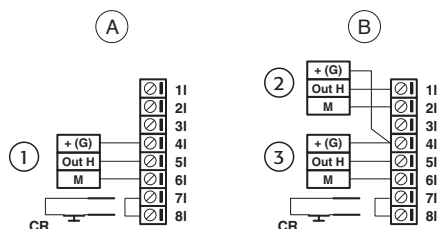

Fig. 7.h

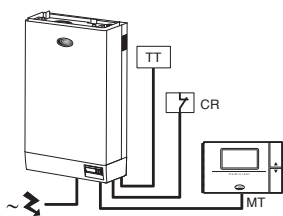

Fig. 7.i

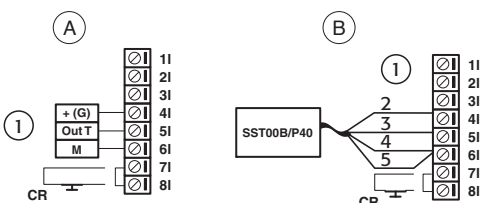

Fig. 7.j

7.4.2 Type H control module with modulating action

The humidifier with modulating action is fitted with solid-state relays, and its capacity can be varied from zero to 100% depending on the control requirements. In this case too, the humidifier can be connected via RS485 to the CAREL Humivisor MT remote control panel or a remote supervisor. It can be controlled in the following three different modes.

- a) Slave control, with signal from an external regulator.
 Steam production is managed by an external regulator R (Fig. 7.d) that transmits a modulating signal to the control module; the control module can be programmed to receive alternatively one of the following modulating signals (see THE HUMIDIFIER CONTROLLER):
 - voltage signal: 0 to 1Vdc; 0 to 10Vdc; 2 to 10Vdc;
 - current signal: 0 to 20mA; 4 to 20mA.

The reference (zero) of the external regulator must be connected to terminal 6I on terminal block I and the control signal to terminal 5I (Fig. 5.e).

To avoid disturbances in control, the ground of the external regulator must be connected to the ground of the control.

- b) Autonomous modulating control with ambient relative humidity probe (and possible limiting probe in the outlet duct)

With this configuration (see Fig. 7.f) the main control board, connected to a humidity probe HT, performs complete control according to the humidity measured.

A limiting humidity probe in the outlet duct can also be added (see Fig. 7.g): with this configuration, typical of air handling systems, the main control board, connected to a humidity probe HT, performs complete control, as well as limiting the steam production depending on the value of relative humidity in the outlet duct, measured using the special probe CH.

The diagrams shown in Fig. 7.h indicate the connections to be made using CAREL probes, for:

- just one relative humidity probe;
- a limiting humidity probe in the outlet duct.

CAREL probes available for rooms

ASWH100000

for air ducts

ASDH100000

ASDH200000

for special applications

ASPC230000

ASPC110000

The control can be connected to non-CAREL active probes; see Using different brand probes.

Legenda:

- | | |
|----|---|
| 1. | HT: CAREL humidity probe (intake probe) |
| 2. | CH: CAREL limit probe (outlet probe) |
| 3. | HT: CAREL humidity probe (intake probe) |

7.4.3 Type T control module for steam baths with modulating action

The control of this appliance features autonomous internal control, and is connected to a temperature probe TT (Fig. 7.i).

This performs complete control according to the temperature measured inside the environment being controlled.

Fig. 7.4.3.2 shows the connection of CAREL probe model ASET030001, with a measurement range of -30T90 °C (Fig. 7.j.A), or SST00B/P40 (Fig. 7.j.B). The CAREL recommended probes have a 0 to 1V output. The control signal must be connected to terminal 5I, whose reference (GND) is represented by terminal 6I. The control can be connected to non-CAREL active probes; see Using different brand probes.

Key:

- | | |
|----|-----------------------------|
| 1. | TT: temperature CAREL probe |
| 2. | red |
| 3. | brown |
| 4. | black |
| 5. | white |

7.5 Other auxiliary contacts

7.5.1 Alarm contact

The humidifier's control module features a voltage-free switching contact for the remote signalling of the presence of one or more anomalous events or alarms.

Connection to the alarm contact (250 Vac; maximum load: 8 A resistive - 2 A inductive) is made using the removable terminal block H, as per Fig. 7.l.



Fig. 7.l

7.5.2 Dehumidification contact

In the advanced version with internal control and humidity transducer, the control module features a voltage-free NO contact, the closing of which can, if required, be programmed to activate an external dehumidification device: in this case the appliance assumes the functions of a complete ambient relative humidity control.

Connection to the dehumidification contact (250 Vac; maximum load: 8 A resistive - 2 A inductive) is made using the removable terminal block G, as per Fig. 7.m.



Fig. 7.m

7.5.3 Remote terminal/supervisory system

The humidifier's control module can be connected to an RS485 serial line, as per the diagram in Fig. 7.n, or alternatively to:

- a CAREL Humivisor remote control panel (see specific instruction manual), which can be connected to four different humidifiers;
- a remote supervisory system.

The transmission line can reach a maximum distance of 1000 metres between the two most distant points.

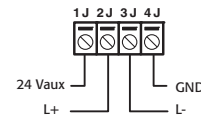

Fig. 7.n

7.5.4 Using different brand probes

Different brand probes can be used, with output signals selected, by programming the parameter A2, (see THE HUMIDIFIER CONTROLLER) from the following:

- voltage signal: 0 to 1 Vdc; 0 to 10 Vdc; 2 to 10 Vdc;
- current signal: 0 to 20 mA; 4 to 20 mA.

In addition, the maximum and minimum values must be programmed for the signal (parameters A3 and A4 for the room probe; A7 and A8 for the outlet probe).

The probes can be powered at the following voltages:

- 12 V stabilised at terminal 4l;
- 32 Vdc from the rectifying of 24 Vac at terminal 3l.

The control signals must be connected:

- for the control probe HT (TT in the case of controls for steam baths) to terminal 5l, whose reference ground (GND) is terminal 6l;
- for the limiting probe CH, to terminal 1l, whose reference ground (GND) is terminal 2l.



IMPORTANT WARNINGS:

- To avoid disturbances to control, the ground of the probes or the external regulators must be electrically connected to the ground of the appliance's control;
- For humidifier operation terminals 7l and 8l must be connected by an enabling contact or a jumper (default solution). If terminals 7l and 8l are not connected, all internal and external devices commanded by the control are disabled.

7.6 Checks

The following conditions represent correct electrical connection:

- the rated voltage of the appliance corresponds to the voltage on the specification plate;
- the fuses installed are suitable for the line and the voltage of the power supply;
- a line cut-off switch has been installed to enable power to the humidifier to be disconnected;
- the electrical connections have been made as per the diagrams;
- the power cable is fastened to the tear-proof cable clamp;
- terminals 7l and 8l are connected by jumper or an enabling contact;
- the ground of any non-CAREL probes is electrically connected to the ground of the control;
- if the appliance is commanded by an external regulator, the ground of the signal is electrically connected to the controller's ground.

7.7 Wiring diagrams for the connection of the heating elements

Star three-phase connection (6-10 kg/h) (13.2-22 lbr/h)

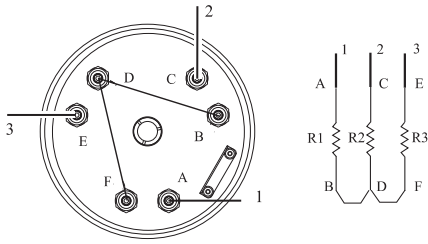

Fig. 7.0.a

Delta three-phase connection (6-10 kg/h) (13.2-22 lbr/h)

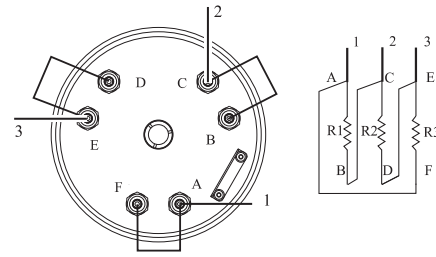

Fig. 7.0.b

Parallel single-phase connection (6 kg/h) (13.2 lbr/h)

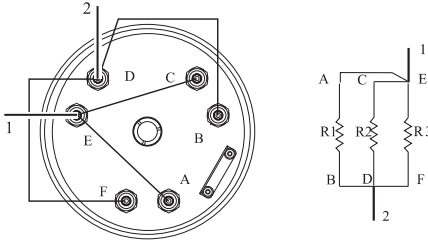

Fig. 7.0.c

Star three-phase connection (2-4 kg/h) (4.4-8.8 lbr/h)

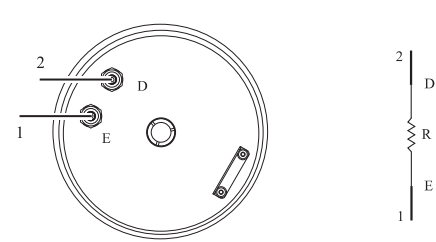

Fig. 7.0.d

Delta three-phase connection (20-27 kg/h) (44-59.5 lbr/h) 208/230 V

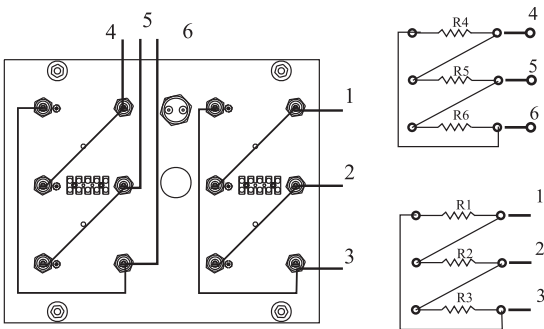

Fig. 7.0.e

Sstar three-phase connection (20-27-40 kg/h) (44-59.5-88 lbr/h) 400/460/575 V

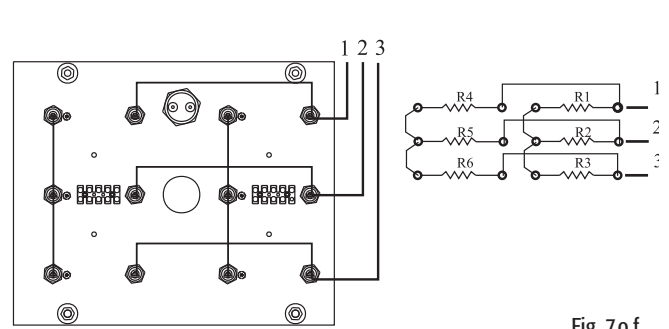

Fig. 7.0.f

Star three-phase connection (60 kg/h) (132.2 lbr/h) 460 V

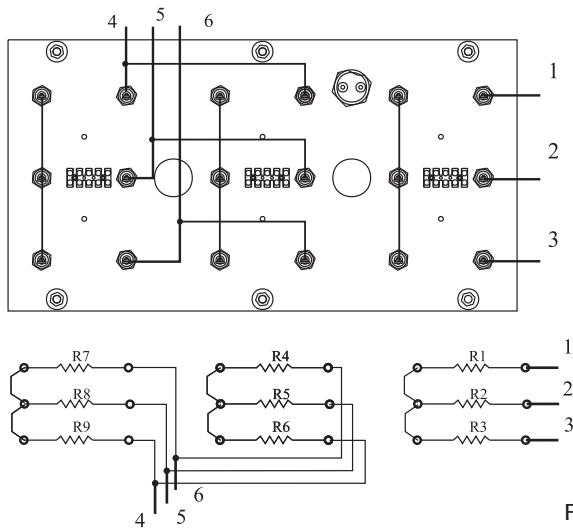

Fig. 7.0.g

Star three-phase connection (60 kg/h) (132.2 lbr/h) 400/575 V

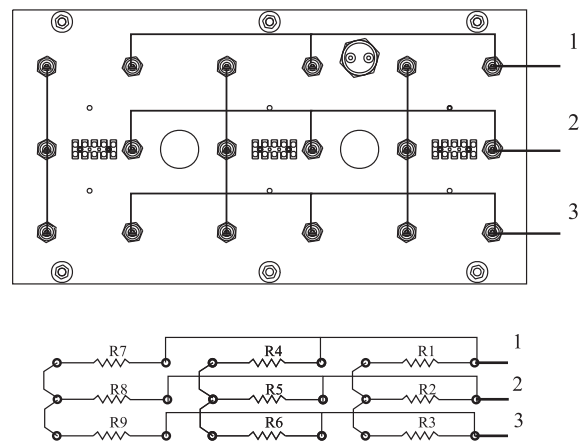

Fig. 7.0.h

Key

1-2-3-4-5-6	three-phase power supply terminals
1-2	single-phase power supply terminals
Fig. 7.0.a	three-phase star connection (6-10Kg/h) (13.2-22 lbr/h)
Fig. 7.0.c	single-phase parallel connection (6kg/h) (13.2 lbr/h)
Fig. 7.0.b	three-phase delta connection (6-10kg/h) (13.2-22 lbr/h)
Fig. 7.0.d	single-phase connection (2-4kg/h) (4.4-8.8 lbr/h)

Fig. 7.0.e	three-phase parallel connection (20-27Kg/h) (44-59.5 lbr/h) 208/230 V
Fig. 7.0.f	three-phase star connection (20-27-40Kg/h) (44-59.5-88 lbr/h) 400/460/575 V
Fig. 7.0.g	three-phase star connection (60 Kg/h)(132.2lbr/h) 460 V
Fig. 7.0.h	three-phase star connection (60 Kg/h) 400/575 V

Table 7.7c

7.8 Single-phase wiring diagram for 2-4kg/h (4.4-8.8lbr/h) humidifiers with type C control module

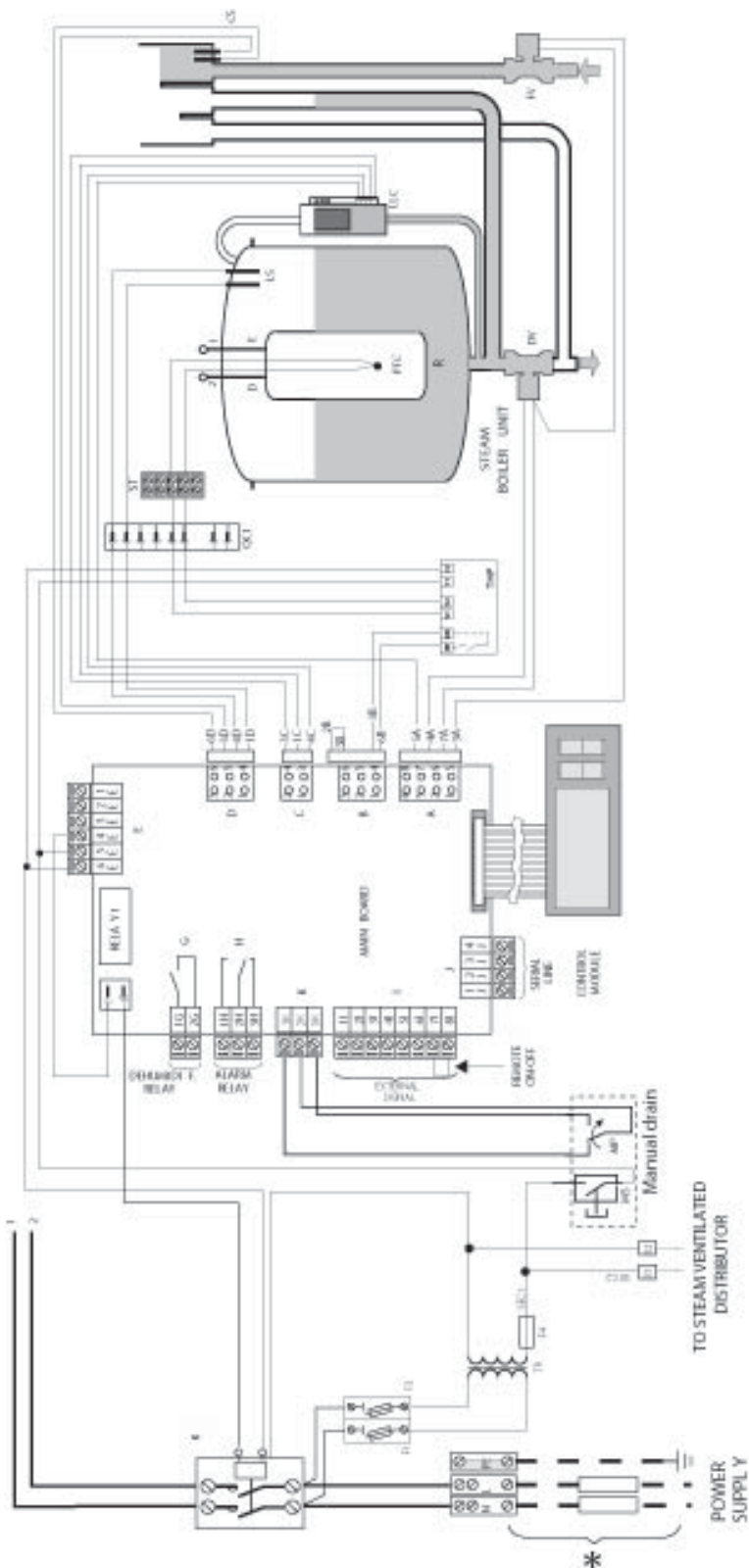

* Carried out by the installer

TB	Terminal block
THP	Motor Protector
QC1-QC2	Quick connectors
K	Contactors
LLC	Level switches
ST	Sensor terminal block
F1-F2	Power fuses
FV	Fill valve
PTC	Heater temperature sensor
TR	Transformer
DV	Drain valve
LS	High level electrodes
MP	Manual drain
CS	Conductivity meter electrodes
MS	Manual switch
R	Electric heating element

Fig. 7.p.a

WARNING:
BRIDGING CONNECTION see Fig. 7o.d

7.9 Single-phase wiring diagram for 2-4kg/h (4.4-8.8lbr/h) humidifiers with type H or T control module

* Carried out by the installer

TB	Terminal block
FV	Fill valve
PTC	Heater temperature sensor
K	Contactors
DV	Drain valve
NTC	Water temperature sensor
F1-F2	Power fuses
LS	High level electrodes
FAN	Fan
TR	Transformer
CS	Conductivity meter electrodes
FSB	Fan control board
C	Filter
SSR	Solid state relay
MS	Manual switch
R	Electric heating element
S2	Circuit breaker
THP	Motor Protector
QC1-QC2	Quick connectors
MP	Manual drain
LLC	Level switches
ST	Sensor terminal block

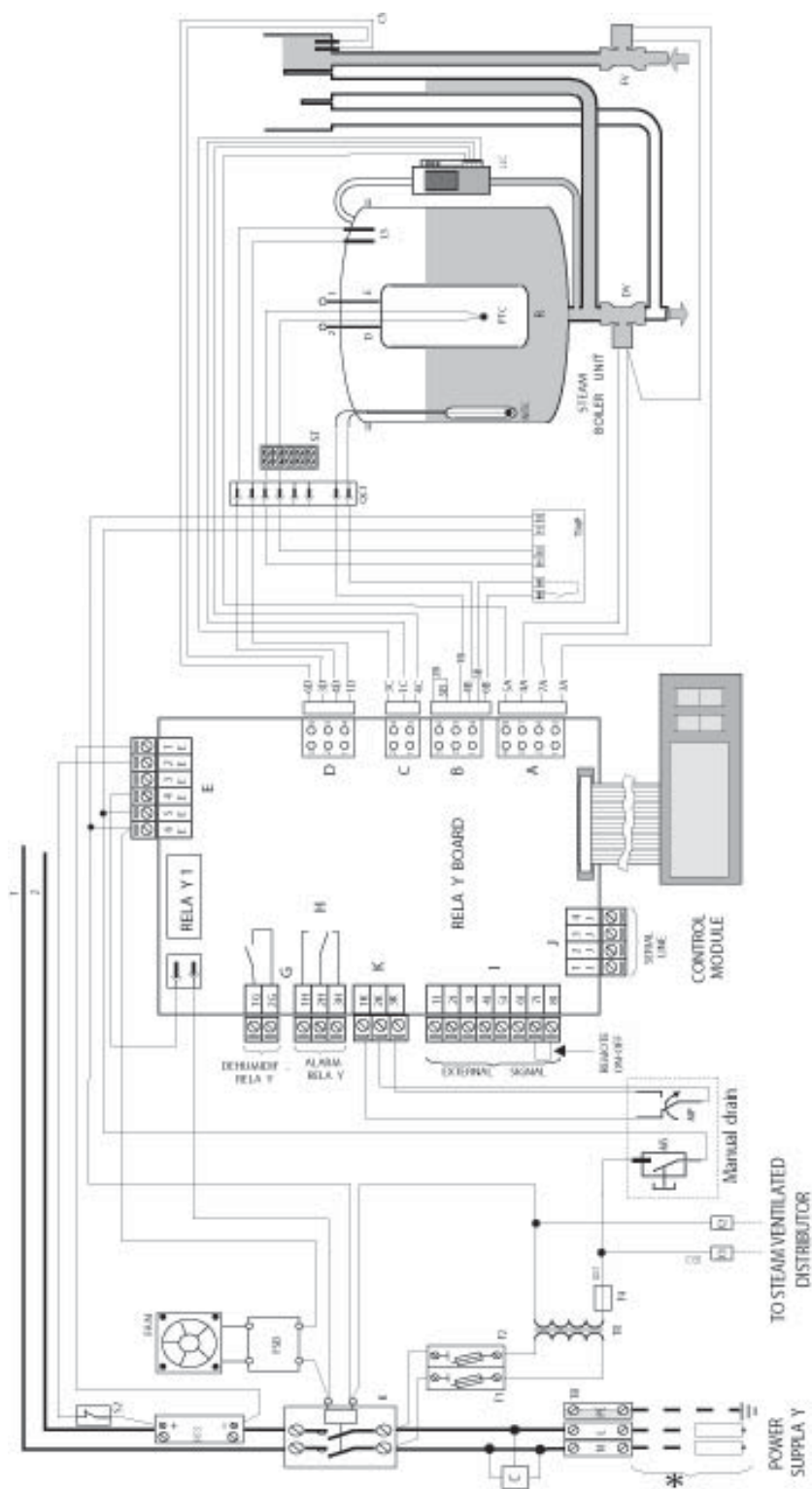

Fig. 7.p.b

WARNING:
BRIDGING CONNECTION see Fig. 7.o.d

7.10 Single-phase wiring diagram for 6kg/h (13.2lbr/h) humidifiers with type C control module

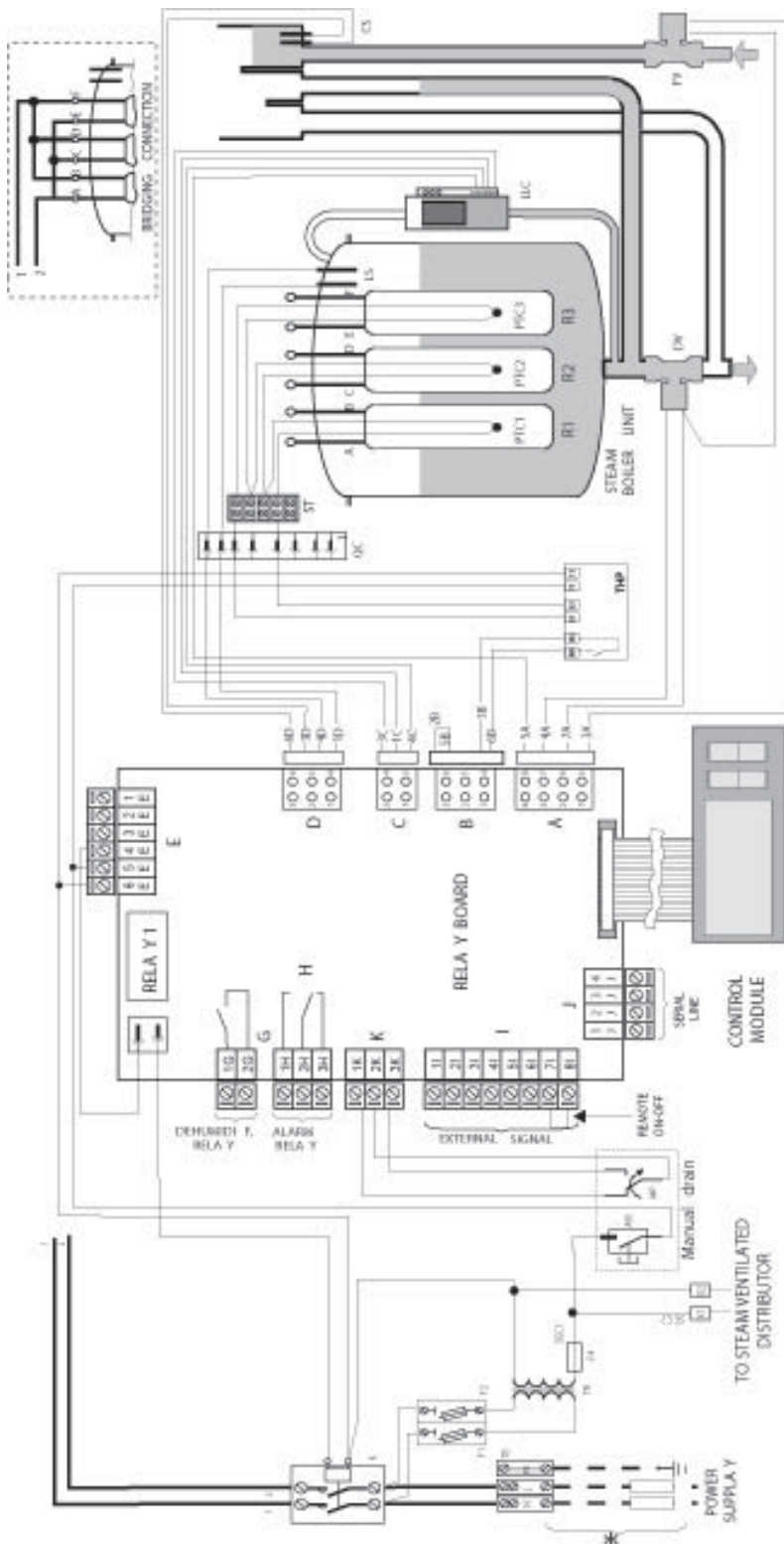

Fig. 7.p.c

WARNING:
BRIDGING CONNECTION see Fig. 7.o.c

* Carried out by the installer

TB	Terminal block
THP	Motor Protector
R1-R2-R3	Electric heating element
K	Contact
LLC	Level switch
QC1-QC2	Quick connectors
F1-F2	Power fuses
FV	Fill valve
ST	Sensor terminal block
TR	Transformer
DV	Drain valve
PTC-PTC2-PTC3	Heater temperature sensors
LS	High level electrodes
MP	Manual drain
MS	Manual switch
CS	Conductivity meter electrodes

7.11 Single-phase wiring diagram for 6kg/h (13.2lbr/h) humidifiers with type H or T control module

* Carried out by the installer

TB	Terminal block
FV	Fill valve
PTC1-PTC2-PTC3	Heater temperature sensors
K	Contactors
DV	Drain valve
NTC	Water temperature sensor
F1-F2	Power fuses
LS	High level electrodes
FAN	Fan
TR	Transformer
CS	Conductivity meter electrodes
FSB	Fan control board
C	Filter
RSS	Solid state relay
MS	Manual switch
R1-R2-R3	Electric heating element
THP	Motor Protector
QC1-QC2	Quick connectors
LLC	Level switch
ST	Sensor terminal block
MP	Manual drain
S2	Circuit breaker

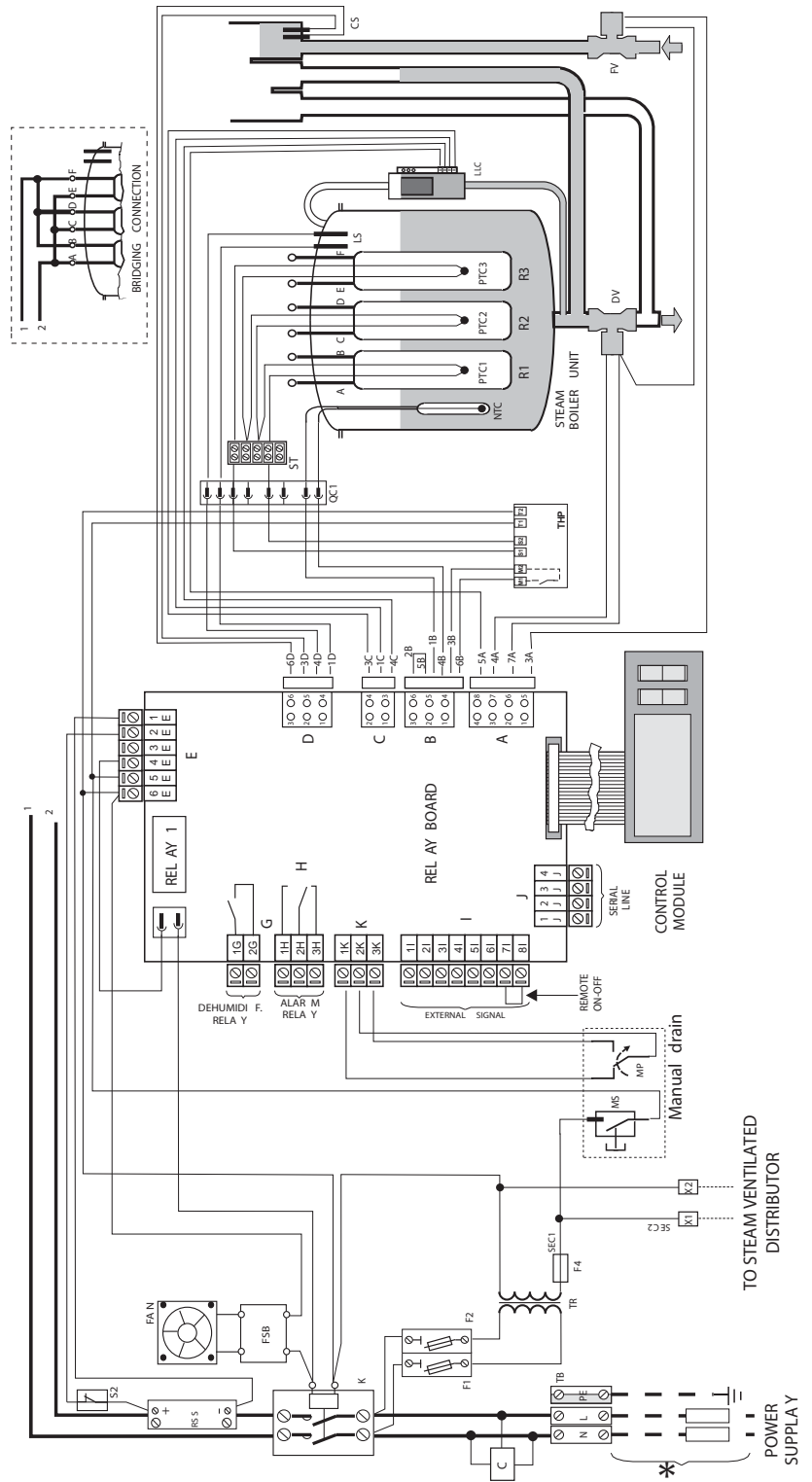

Fig. 7.p.d

WARNING:
BRIDGING CONNECTION see Fig. 7.0.C

7.12 Three-phase wiring diagram for 6-10Kg/h (13.2-22lbr/h) humidifiers with type C control module

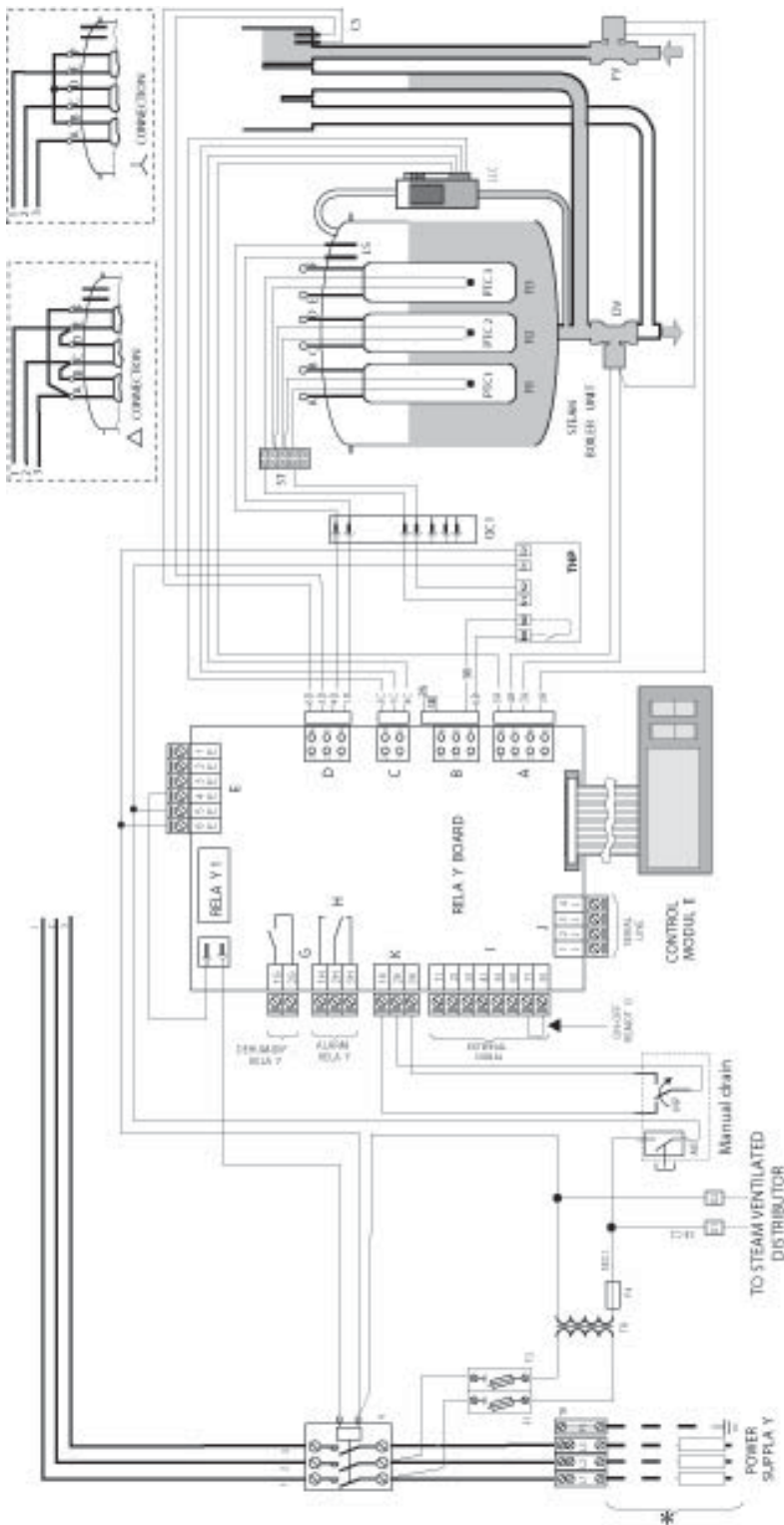

Fig. 7.p.e

* Carried out by the installer

TB	Terminal block
THP	Motor Protector
R1-R2-R3	Electric heating element
K	Contactor
LLC	Level switch
QC1-QC2	Quick connectors
F1-F2	Power fuses
FV	Fill valve
ST	Sensor terminal block
TR	Transformer
DV	Drain valve
PTC1-PTC2-PTC3	Heater temperature sensors
LS	High level electrodes
MP	Manual drain
CS	Conductivity meter electrodes
MS	Manual switch

WARNING:
BRIDGING CONNECTION see Fig. 7.o.a e 7.o.b

7.13 Three-phase wiring diagram for humidifiers with type H or T control module

* Carried out by the installer

TB	Terminal block
FV	Fill valve
PTC1-PTC2-PTC3	Heater temperature sensors
K	Contact
DV	Drain valve
NTC	Water temperature sensor
F1-F2	Power fuses
LS	High level electrodes
FAN	Fan
TR	Transformer
CS	Conductivity meter electrodes
FSB	Fan control board
C	Filter
RSS1-RSS2	Solid state relay
MS	Manual switch
R1-R2-R3	Electric heating element
LLC	Level switch
QC1-QC2	Quick connectors
THP	Motor Protector
MP	Manual drain
S2	Circuit breaker

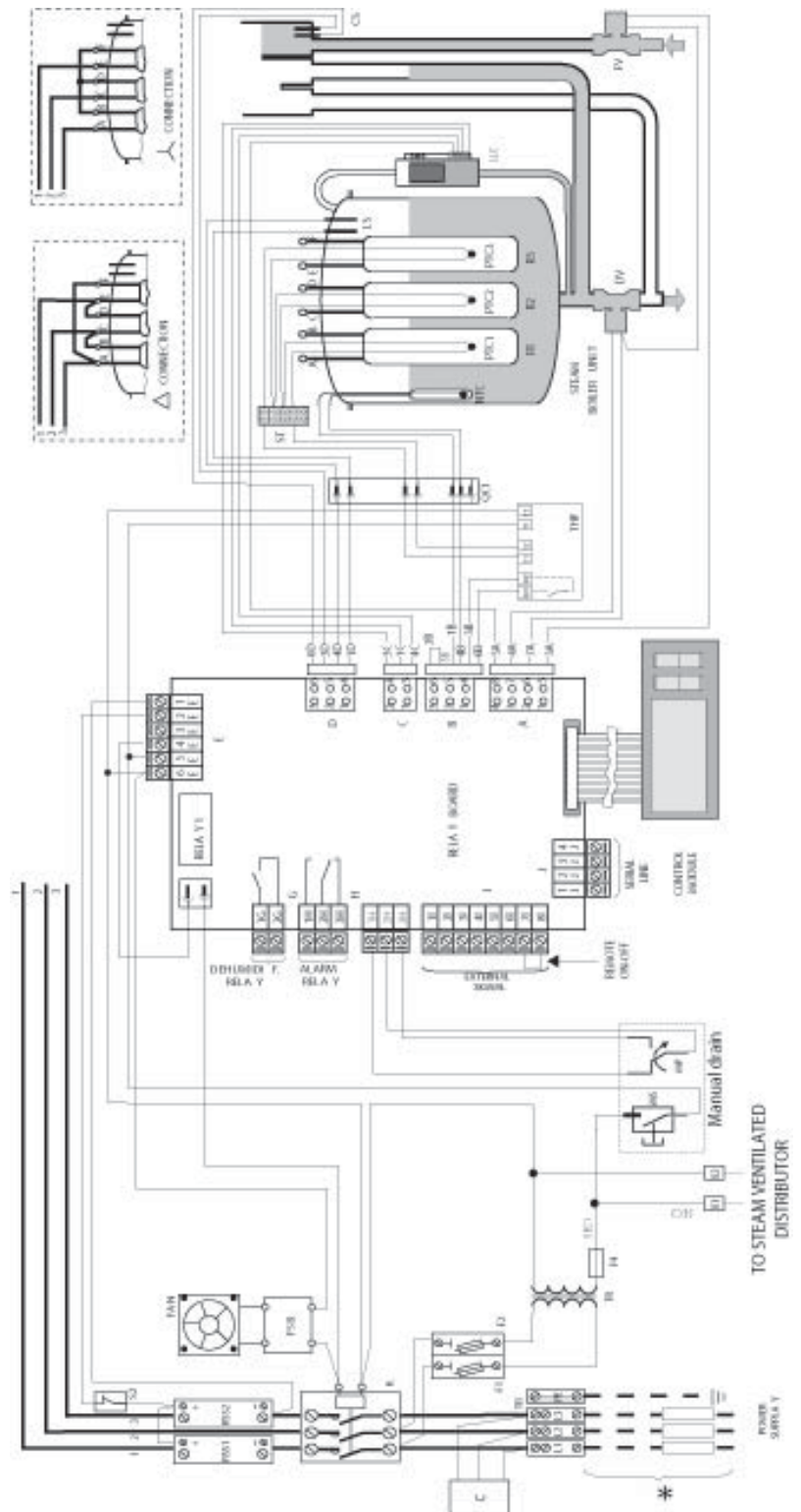

Fig. 7.p.f

WARNING:
BRIDGING CONNECTION see fig. 7.o.a. e 7.o.b

**7.14 Three-phase electrical diagram for 20 (44lb/h)
(208-230-400-460-575V) 27-40Kg/h (59.5-88lb/h)
(400-460-575V) humidifiers with type C control module
400-460-575 V**

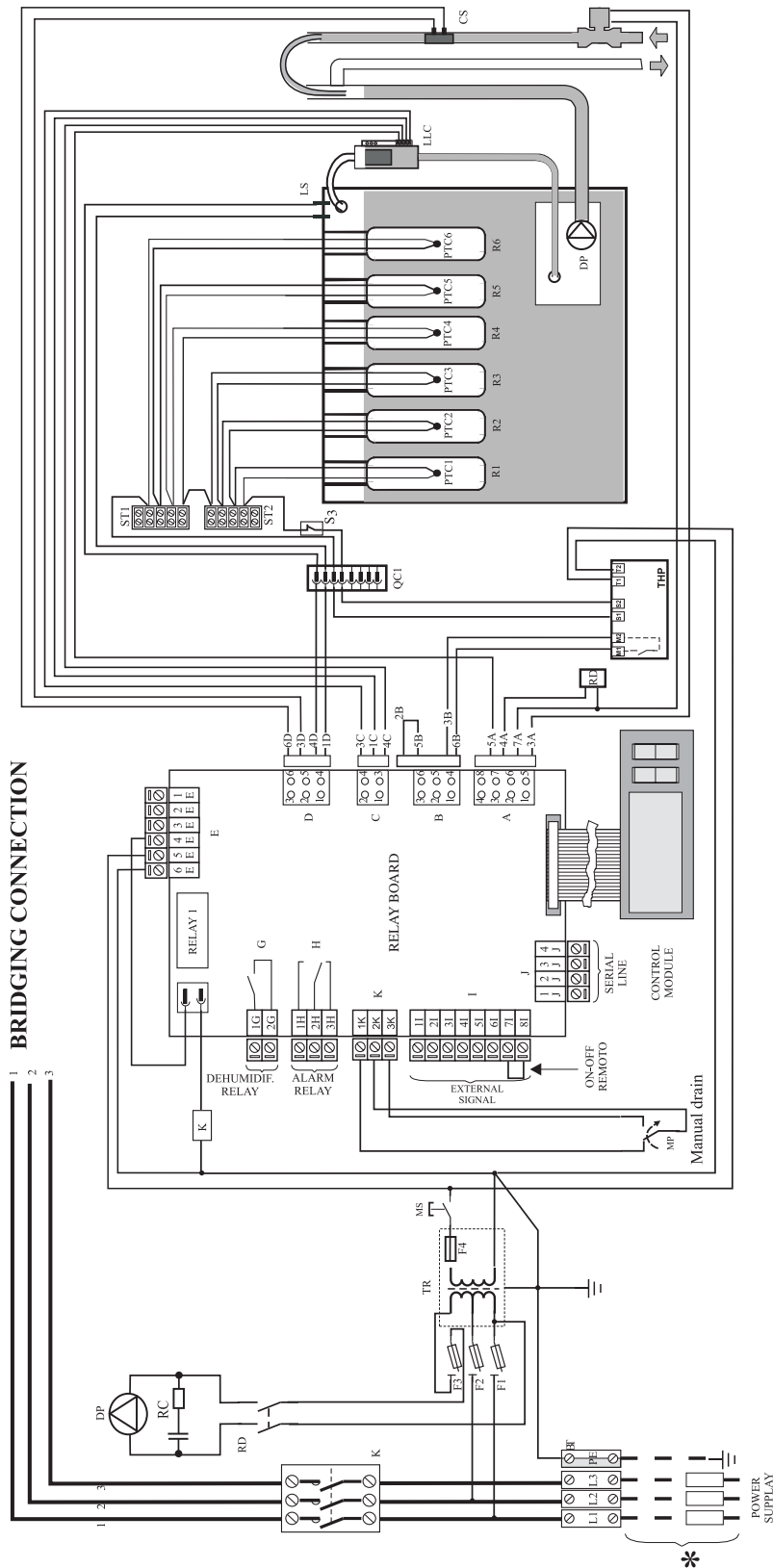

Fig. 7.p.g

* Carried out by the installer

TB	Terminal block
FV	Fill valve
PTC1 to PTC6	Heater temperature sensors
K	Contactors
DP	Drain pump
FAN E.P.	Fan electrical panel
F1-F2-F3	Power fuses
LS	High level electrodes
F4	Low voltage fuse
TR	Transformer
CS	Conductivity meter electrodes
THP	Motor Protector
MS	Manual switch
RD	Pump control relay
LLC	Level switches
R1 to R6	Electric heating element
MP	Manual drain
QC1	Quick connectors
S3	Circuit breaker

WARNING:
BRIDGING CONNECTION see Fig. 7.o.f

7.15 Three-phase electrical diagram for 20 (44lbr/h) (208-230-400-460-575V) 27-40Kg/h (59.5-88lbr/h) (400-460-575V) humidifiers with type H control module 400-460-575 V

* Carried out by the installer

TB	Terminal block
FV	Fill valve
PTC1 to PTC6	Heater temperature sensors
K	Contactors
DP	Drain pump
FAN E.P.	Fan electrical panel
F1-F2-F3	Power fuses
LS	High level electrodes
F4	Low voltage fuse
TR	Transformer
CS	Conductivity meter electrodes
THP	Motor Protector
MS	Manual switch
RD	Pump control relay
NTC	Water temperature sensor
LLC	Level switches
R1 to R6	Electric heating element
RSS1-RSS2	Solid state relay
MP	Manual drain
QC1	Quick connectors
C	Filter
S2-S3	Circuit breaker

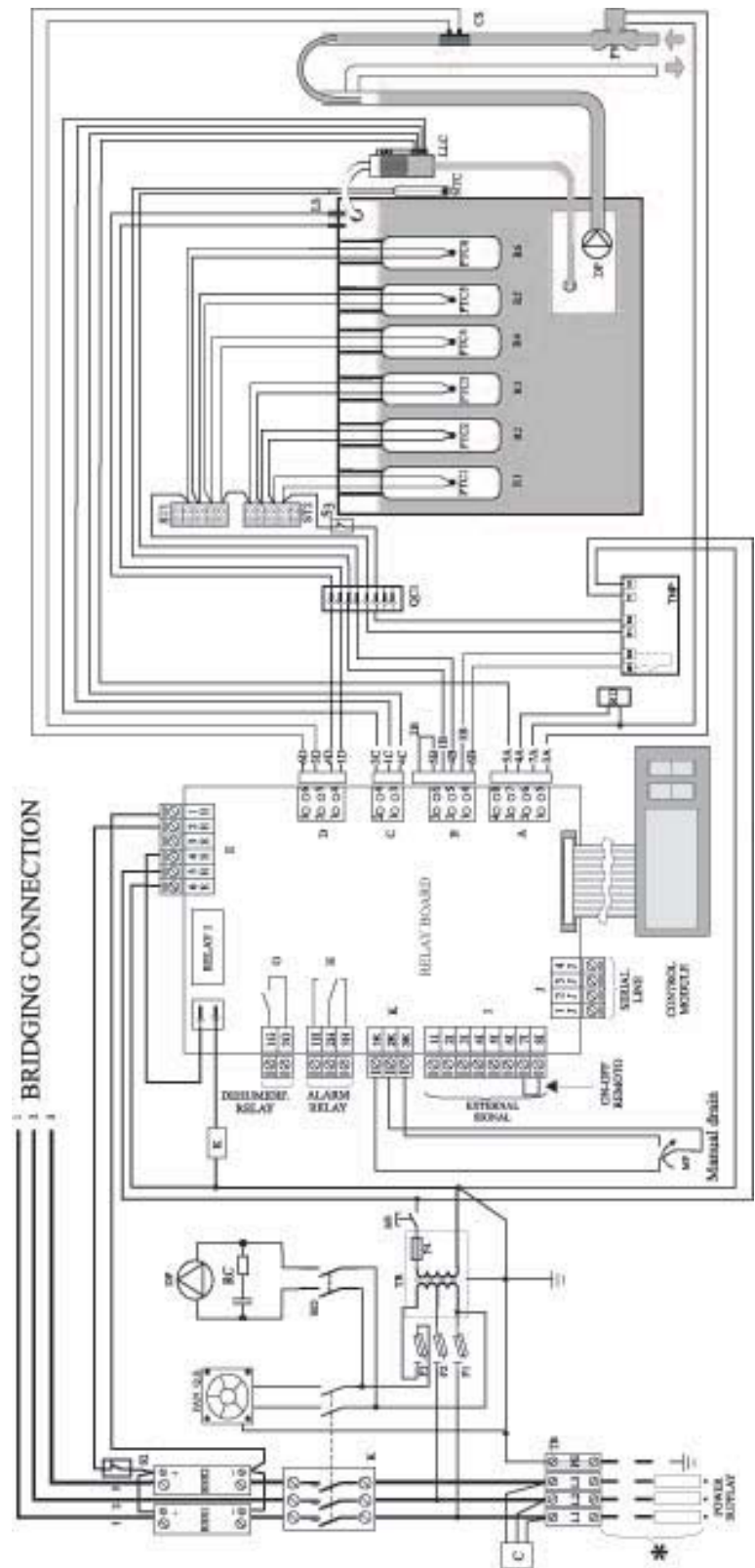
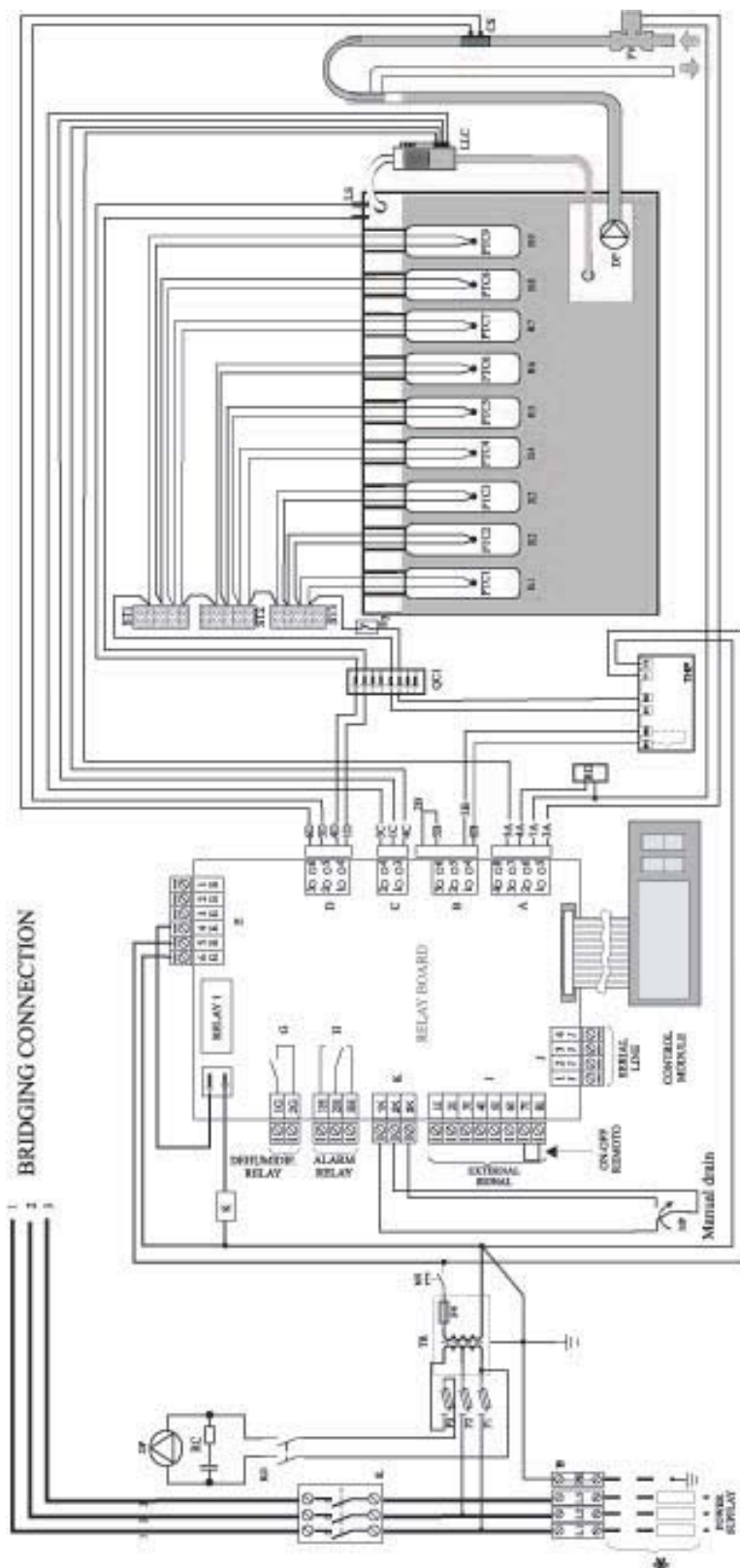

Fig. 7.p.h

WARNING:
BRIDGING CONNECTION see Fig. 7.o.f

7.16 Three-phase electrical diagram for 60Kg/h (132.2lbr/h) humidifiers with type C control module 400-575 V



* Carried out by the installer

TB	Terminal block
FV	Fill valve
PTC1...PTC9	Heater temperature sensors
K	Contact
DP	Drain pump
FAN E.P.	Fan electrical panel
F1-F2-F3	Power fuses
LS	High level electrodes
F4	Low voltage fuse
TR	Transformer
CS	Conductivity meter electrodes
THP	Motor Protector
MS	Manual switch
RD	Pump control relay
LLC	Level switches
R1 to R9	Electric heating element
MP	Manual drain
QC1	Quick connectors
S3	Circuit breaker

ENGLISH

Fig. 7.p.i

WARNING:
BRIDGING CONNECTION see Fig. 7.o.h

7.17 Three-phase electrical diagram for 60Kg/h (132.2lbr/h) humidifiers with type H control module 400-575 V

* Carried out by the installer

TB	Terminal block
FV	Fill valve
PTC1 to PTC9	Heater temperature sensors
K	Contactors
DP	Drain pump
FAN E.P.	Fan electrical panel
F1-F2-F3	Power fuses
LS	High level electrodes
F4	Low voltage fuse
TR	Transformer
CS	High level electrodes
THP	Motor Protector
MS	Manual switch
RD	Pump control relay
NTC	Water temperature sensor
LLC	Level switches
R1 to R9	Electric heating element
RSS1-RSS2	Solid state relay
MP	Manual drain
QC1	Quick connectors
C	Filter
S2-S3	Circuit breaker

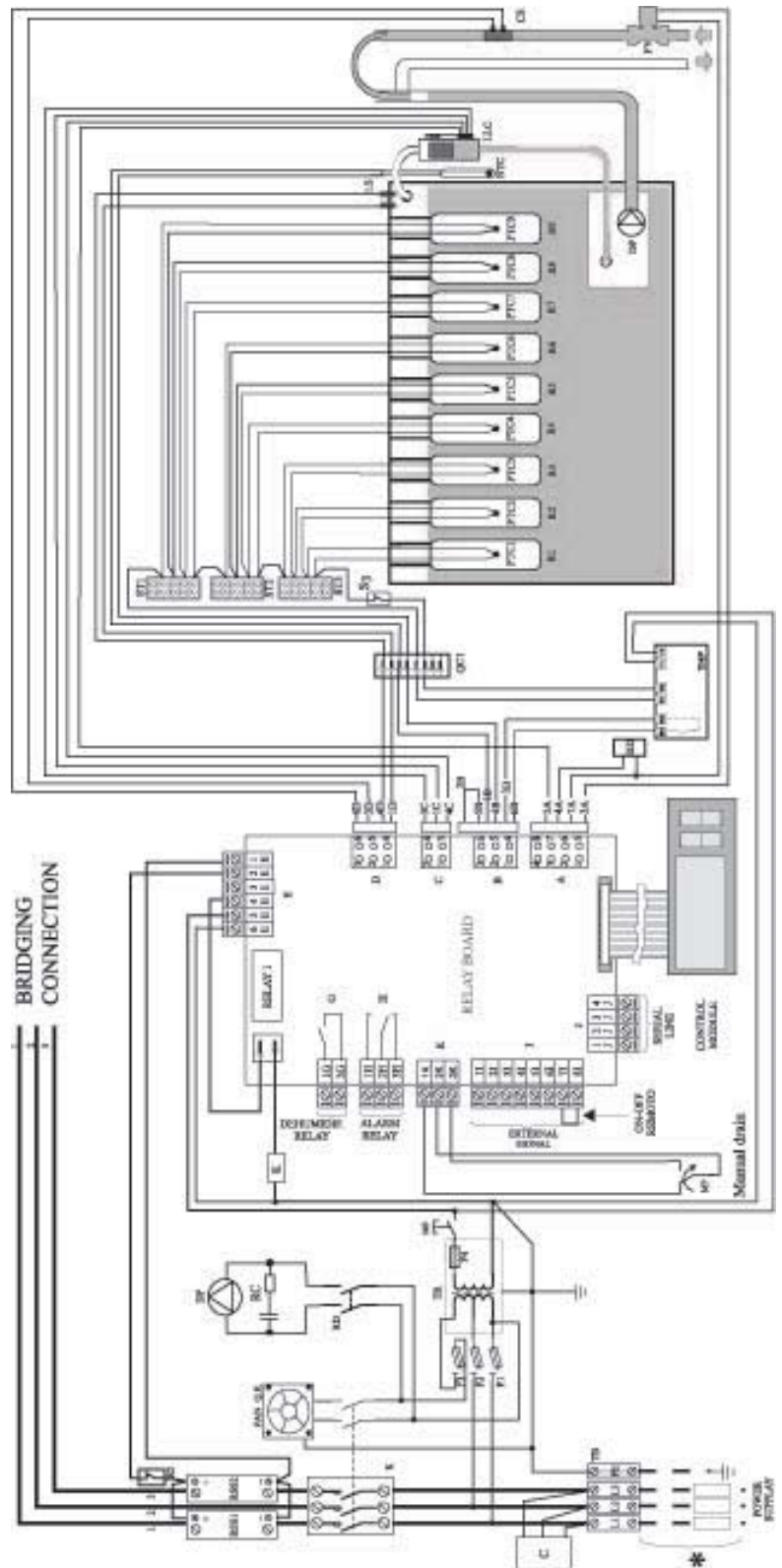
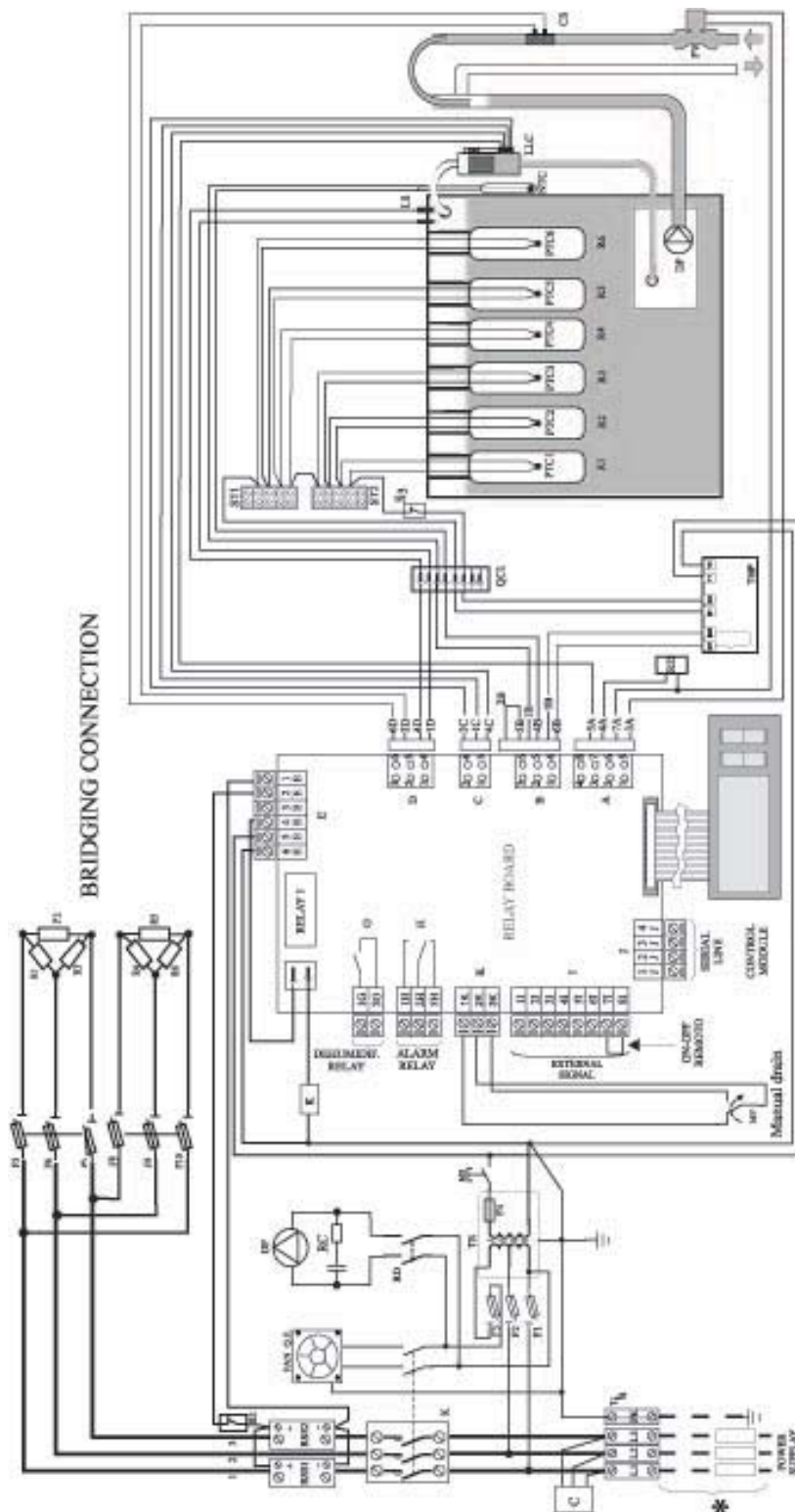

Fig. 7.pj

WARNING:
BRIDGING CONNECTION see Fig. 7.o.h

7.18 Three-phase electrical diagram for 27Kg/h (59.5lbr/h) humidifiers with type H control module at 208 - 230 V



* Carried out by the installer

TB	Terminal block
FV	Fill valve
PTC1 to PTC6	Heater temperature sensors
K1-K2	Contactors
DP	Drain pump
FAN E.P.	Fan electrical panel
F1-F2-F3	Power fuses
LS	High level electrodes
F4	Low voltage fuse
TR	Transformer
CS	Conductivity meter electrodes
THP	Motor Protector
MS	Manual switch
RD	Pump control relay
NTC	Water temperature sensor
LLC	Level switches
R1 to R6	Electric heating element
RSS1-RSS2	Solid state relay
MP	Manual drain
QC1	Quick connectors
C	Filter
F5 to F10	load protection fuses
S2-S3	Circuit breaker

Fig. 7p.k

WARNING:
BRIDGING CONNECTION see Fig. 7o.e

7.19 Three-phase electrical diagram for 27Kg/h (59.5lbr/h) humidifiers with type H control module at 208 - 230 V

* Carried out by the installer

TB	Terminal block
FV	Fill valve
PTC1 to PTC6	Heater temperature sensors
K1-K2	Contactors
DP	Drain pump
FAN E.P.	Fan electrical panel
F1-F2-F3	Power fuses
LS	High level electrodes
F4	Low voltage fuse
TR	Transformer
CS	Conductivity meter electrodes
THP	Motor Protector
MS	Manual switch
RD	Pump control relay
LLC	Level switches
R1 to R6	Electric heating element
MP	Manual drain
QC1	Quick connectors
F5...F10	load protection fuses
S3	Circuit breaker

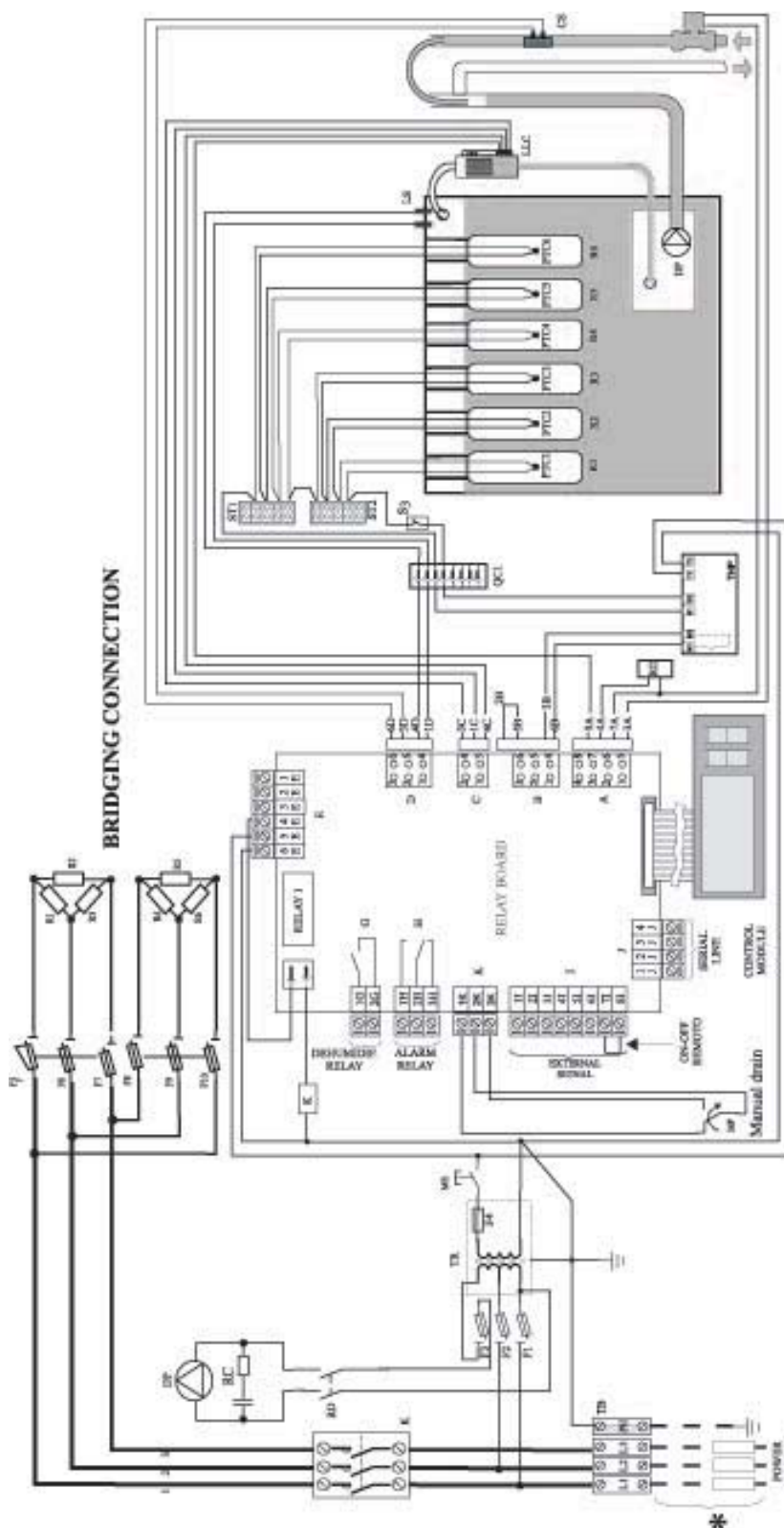

Fig. 7p.l

WARNING:
BRIDGING CONNECTION see Fig. 7.o.e

7.20 Three-phase electrical diagram for 60kg/h (132.2lbr/h) humidifiers with type H control module at 460 V

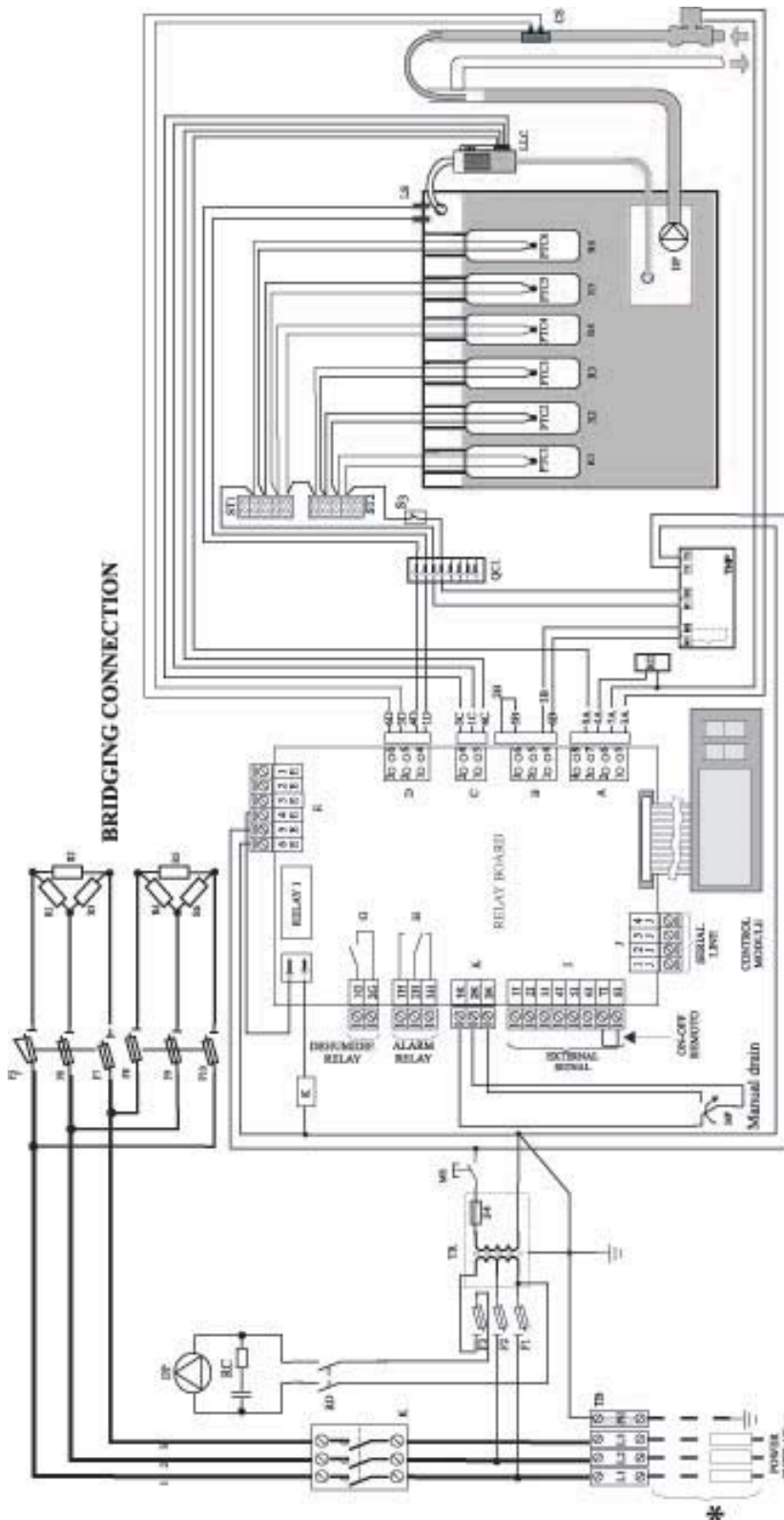

Fig. 7.p.m

WARNING:
BRIDGING CONNECTION see Fig. 7.o.g

* Carried out by the installer

TB	Terminal block
FV	Fill valve
PTC1 to PTC9	Heater temperature sensors
K	Contactor
DP	Drain pump
FAN E.P.	Fan electrical panel
F1-F2-F3	Power fuses
LS	High level electrodes
F4	Low voltage fuse
TR	Transformer
CS	High level electrodes
THP	Motor Protector
MS	Manual switch
RD	Pump control relay
NTC	Water temperature sensor
LLC	Level switches
R1 to R9	Electric heating element
RSS1-RSS2	Solid state relay
MP	Manual drain
QC1	Quick connectors
C	Filter
F5 to F10	load protection fuses
S2-S3	Circuit breaker

7.21 Three-phase electrical diagram for 60kg/h (132.2lbr/h) humidifiers with type C control module at 460 V

* Carried out by the installer

TB	Terminal block
FV	Fill valve
PTC1 to PTC9	Heater temperature sensors
K	Contactors
DP	Drain pump
FAN E.P.	Fan electrical panel
F1-F2-F3	Power fuses
LS	High level electrodes
F4	Low voltage fuse
TR	Transformer
CS	Conductivity meter electrodes
THP	Motor Protector
MS	Manual switch
RD	Pump control relay
LLC	Level switches
R1 to R9	Electric heating element
MP	Manual drain
QC1	Quick connectors
F5 to F10	load protection fuses
S3	Circuit breaker

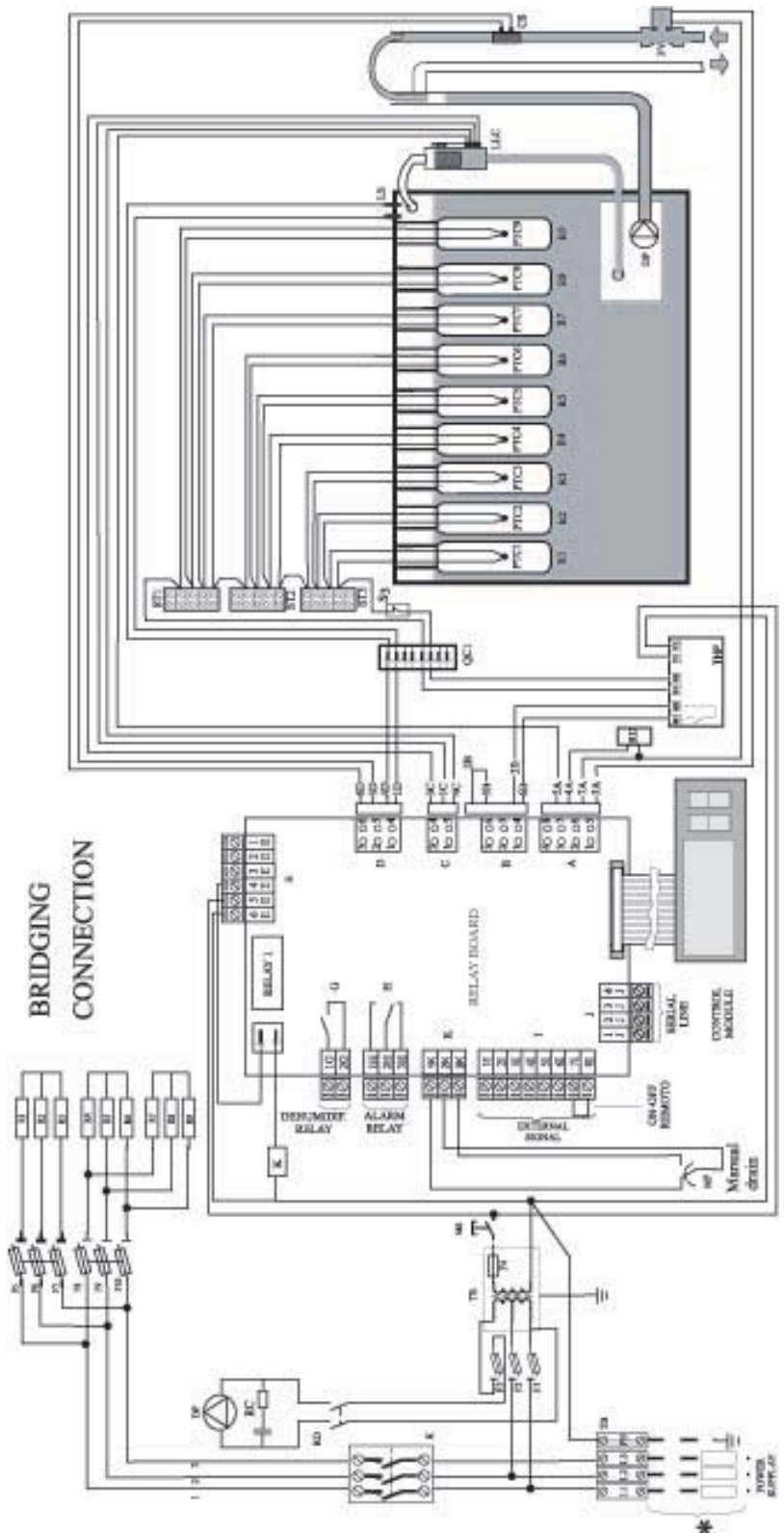

Fig. 7.p.n

WARNING:
BRIDGING CONNECTION see Fig. 7.o.g

8. STEAM DISTRIBUTION

For optimal performance of the humidifier, the steam produced must be introduced into the room/duct in a uniform way, without projecting droplets and without noticeable condensation, using ventilated steam distributors or linear distributors. The steam distributor must be chosen according to the place where the steam is introduced. If the steam is to be distributed directly into the environment (rooms, warehouses, etc.), the ventilated steam distributors used (optional) should be fitted with a motorised fan. If, on the other hand, the steam is to be introduced into a duct or air handling system, linear distributors must be used, which exploit the speed of the air itself for distribution.

8.1 Ambient steam distribution: ventilated steam distributors

Ventilated steam distributors, used to distribute steam directly into the environment, can be mounted onto the humidifier (see Fig. 8.a) or positioned separately and connected to the humidifier (see Fig. 8.b) using steam pipes.

The drawings show the minimum recommended distances to prevent the flow of humidified air from coming into direct contact with persons, lights, electrical appliances, false ceilings and cold surfaces before the steam is completely absorbed by the environment.

For further details on the mounting and use of ventilated steam distributors, please refer to the specific instruction manual.

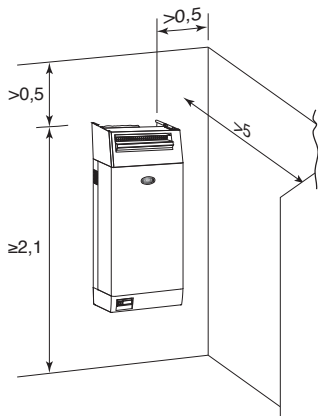

Fig. 8.a

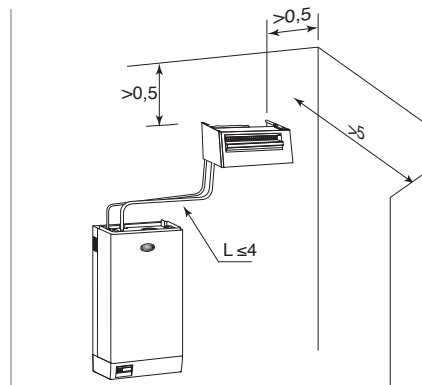

Fig. 8.b

8.2 Steam distribution in cold rooms

It is possible to humidify a cold room using a ventilated steam distributor, ensuring that this works within the limits of its operating range. The cold room must have an operating temperature between -10°C (14°F) and $+40^{\circ}\text{C}$ (104°F), with a relative humidity of not over 80% rH. If these limits are not possible, the steam can be distributed in the cold room using a linear distributor.

In any case, the steam must not come into direct contact with cold air streams from the cold room's refrigeration unit, to avoid possible re-condensation.

8.3 Ducted steam distribution: linear and concentrated jet distributors (OEM)

For steam distribution in air ducts, the steam distributor must be suitably proportioned to the power of the humidifier and the cross-section of the ducts. For this purpose, CAREL supplies two ranges of linear distributors: one of stainless steel, with plastic ends.

Figures 8.c and 8.d provide the dimensions of CAREL distributors.

Table 8.a indicates the minimum number and model of the distributors recommended for the type of humidifier used.

humidifier fitting \varnothing mm / \varnothing inch	30/ 1.18	30/ 1.18	30/ 1.18	30/ 1.18	40/ 1.57	40/ 1.57	40/ 1.57	2x40/ 2x1.57
humidifier capacity kg/h / lbs/hr	2 / 4.4	4 / 8.8	6 / 13.2	10 / 22	20 / 44	27 / 59.4	40 / 88	60 / 132

distributor fitting mm/ inch ($\varnothing A$)	max. distributor capa- city kg/h / lbs/hr	length (L) mm / inch	code	UR002	UR004	UR006	UR010	UR020	UR027	UR040	UR060
				30 / 1.18	5 / 11	343 / 13.5	DP035D30R0	1	1		
30 / 1.18	8 / 17.6	427 / 16.8	DP045D30R0	1	1	1					
30 / 1.18	12 / 26.4	596 / 23.5	DP060D30R0		1	1	1				
30 / 1.18	18 / 39.6	850 / 33.5	DP085D30R0		1	1	1				
30 / 1.18	18 / 39.6	1048 / 41.3	DP105D30R0		1	1	1		(2)*		
30 / 1.18	18 / 39.6	1245 / 49	DP125D30R0		1	1	1		(2)*		
40 / 1.57	25 / 55	834 / 32.8	DP085D40R0					1	1	(2)*	(4)**
40 / 1.57	35 / 77	1015 / 39.9	DP105D40R0					1	1	(2)*	2
40 / 1.57	45 / 99	1222 / 48.1	DP125D40R0					1	1	1	2
40 / 1.57	45 / 99	1636 / 64.4	DP165D40R0						1	1	2
40 / 1.57	45 / 99	2025 / 79.7	DP205D40R0							1	

Table 8.a

N.B.: if the duct is not wide enough for the distributors can be used (numbers shown in the brackets), splitting the steam hose into two.

* : kit available with 30x40x30 "Y" connector, code UEKY000000 to split one 40 mm/1.57 inch outlet into two 30 mm/1.18 inch outlets;

** : from 01/01/2005, kit available with 40x40x40 "Y" connector for the steam hose, code UEKY40x400, to split one 40 mm/1.57 inch outlet into two 40 mm/1.57 inch outlets.

DP***D**R0 - linear distributors

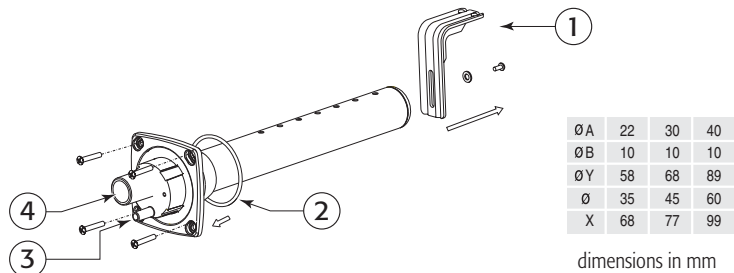

Key:

1	fasten the support where envisaged
2	flange gasket
3	condensate drain
4	steam inlet
5	screws max. dia. "M5"
6	length (see table 8.a)
7	hole in wall
8	use the fastening support, supplied, to ensure the 2° gradient due to the shape of the flange

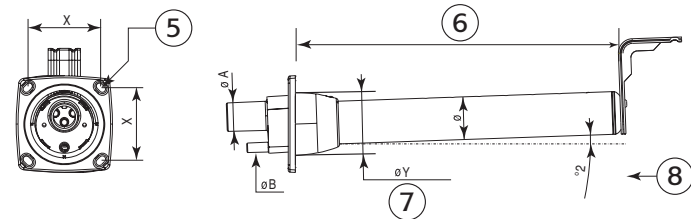

Fig. 8.c

The linear distributors are mounted (see Fig. 8.d):

- by making a series of holes in the wall of the duct, as per the drilling template indicated in Figs.: 8.a or 8.b;
- inserting the distributor with the steam outlet holes facing upwards;
- fastening the flange of the distributor using 3 screws.

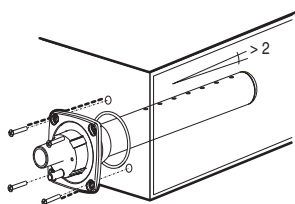

Fig. 8.d

To allow the condensate to return through the drain connection (see Installing the condensate return pipe), mount the distributor at a slight angle (at least 2°-3° Fig. 8.c) with the inlet connection nearer than the closed end, which, for this reason, must be adequately supported.

8.4 Concentrated jet steam distribution (OEM) (only for humidifiers up to 10 Kg/h/22 lbr/h)

For special applications (e.g. steam baths, technological machinery) a plastic OEM concentrated jet distributor is available, with holes (12 or 22 mm)/(0.47 or 0.87 inch) or without, allowing the user to make these according to requirements (see Fig. 8.e).

The OEM distributors can be fitted, horizontally or vertically with the hole facing upwards, onto a support with the same holes as per the drilling template for the aluminium linear distributor (see Fig. 8.e).

N.B.: when using steam tubing with an internal diameter of 30 mm/ 1.18 inch, remove the 22 mm/ 0.87 inch steam inlet section.

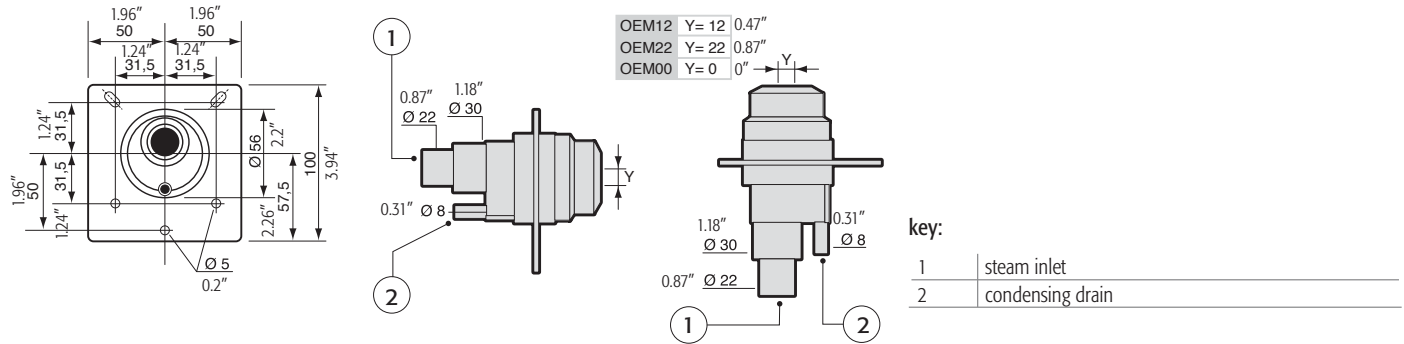

Fig. 8.e

8.5 Positioning linear distributors in the air duct

Depending on the dimensions of the air duct, the distributors must be as long as possible and placed away from curves, branches, changes in cross-section, grilles, filters, fans.

The minimum recommended distance between the steam distributor and the nearest obstacle is around 1 to 1.5 metres/3.28 to 4.92 feet, yet this strongly depends on the operating conditions; it in fact increases as a result of:

- the increase in speed of the air in the duct;
- the increase in relative humidity of the air before and, above all, after humidification;
- the decrease in turbulence.

The distance can be shortened using a series of distributors in parallel.

Refer to the layout and the distances between the distributor and the walls of the duct and/or between two distributors as shown in the following drawings.

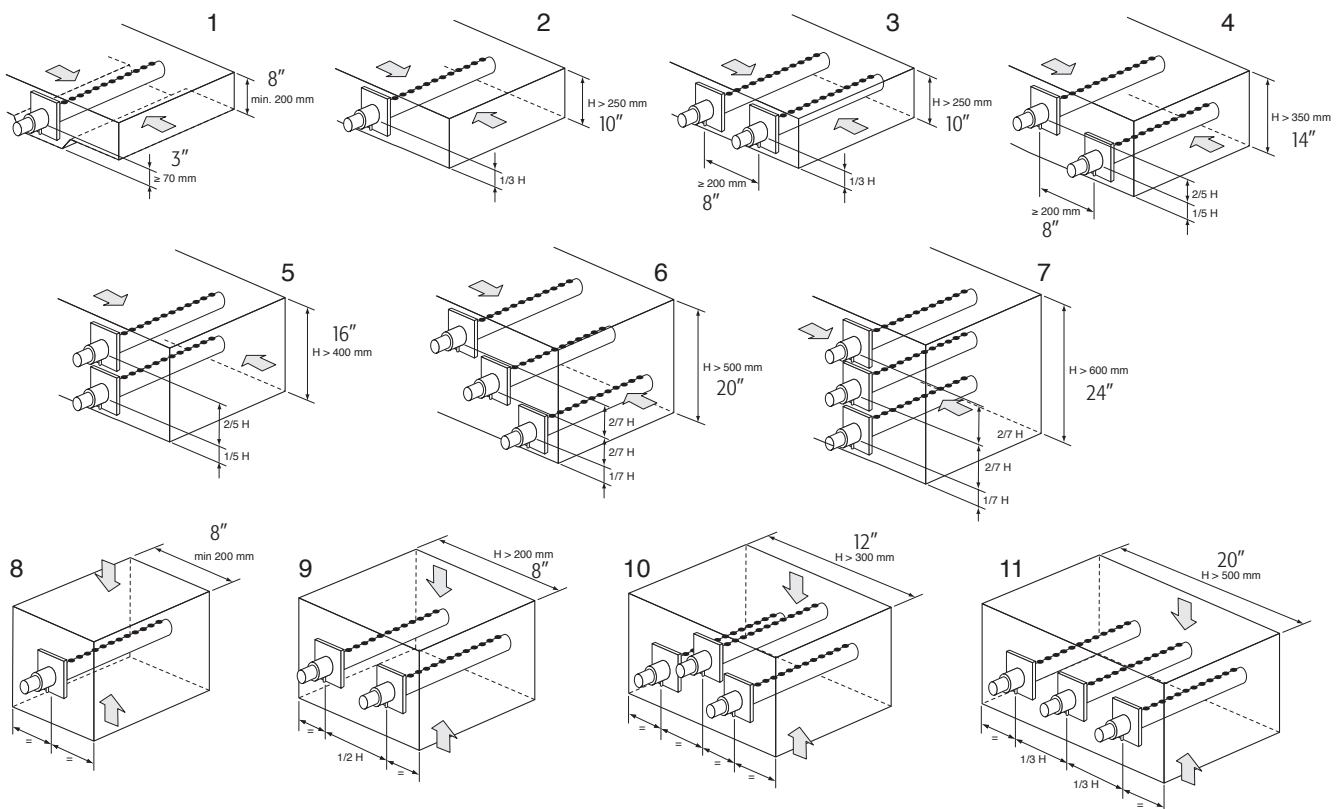

Fig. 8.f

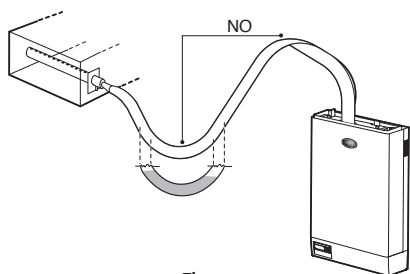

Fig. 8.g

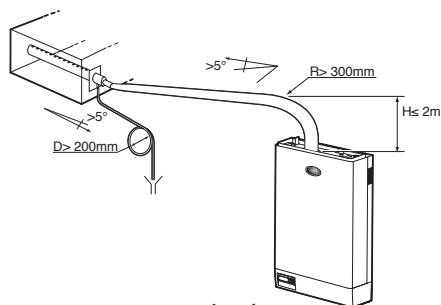

Fig. 8.h

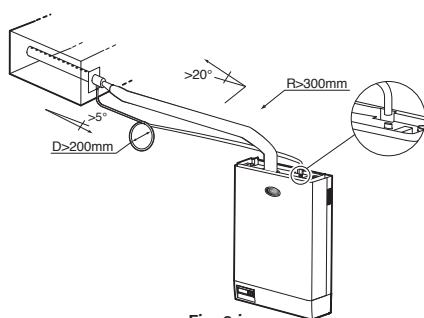

Fig. 8.i

8.6 Installation of the steam pipe

The connection between the humidifier and distributor must be made using a suitable pipe, such as the CAREL flexible pipes. The use of incorrect pipe may lead to fragility and cracks and consequent steam leaks.

The shape of the pipe must be such as to avoid the accumulation of condensate and consequent noise (in the form of gurgling) and loss of efficiency; the course of the pipe must exploit gravity to drain the re-condensed steam back to the cylinder or the distributor.

Avoid the formation of pockets or traps where condensate may form; furthermore, ensure that the pipe is not choked due to tight bends or twisting (see Fig. 8.g).

Fasten the ends of the pipe to the connections on the humidifier and the steam distributor using screw clamps, so that they do not come loose as a result of the temperature.

Depending on the position of the steam distributor, the course of the pipe may be one of the following:

1. upwards with a vertical section at least 300mm/11.8 inch in length, followed by a bend with a minimum radius of 300 mm/11.8 inch, and finally a downward section with a constant slope of not less than 5° (see Fig. 8.h);
2. for very short courses (less than 2 metres/7 feet), a curve with a minimum radius of 300mm/11.8 inch followed by from an upward section with a slope of not less than 20° (see Fig. 8.i).



IMPORTANT WARNING: the length of the steam pipe should be less than 4 m/13.1 feet.

8.7 Installing the condensate return pipe

Due to the re-condensation of part of the steam produced, condensate forms in the steam conveyance pipe and inside the distributor, which must be drained to avoid gurgling, and loss of efficiency.

The condensate is drained by the effect of gravity with the help of a flexible pipe suitable for this purpose. The use of an incorrect pipe can lead to fragility and cracks and consequent water leaks.

To avoid the non-condensed steam from being released through the condensate pipe, a trap must be created by curling a part of the drain pipe.

The end of the condensate pipe can be connected to the nearest drain, with a minimum slope of 5° to assist downflow (see Fig. 8.h).

If there is enough distance from the distributor, the hose can be introduced into the humidifier through the hole on the top of the unit, reaching the boiler supply tank (for 20-60kg/h units), or alternatively connected to the special C fitting supplied, to be tightened to the top of the humidifier, so as to drain the condensate from boiler supply tank (see Fig. 8.i).



IMPORTANT WARNING: for correct functioning, the drain trap must be filled with water before starting the humidifier.

8.8 Checks

The following conditions represent the correct installation of the steam pipe:

- the position of the steam distributor conforms to that described in this chapter, the steam outlet pipe points upwards and the distributor is inclined at least 2° upwards;
- the ends of the pipes are fastened with metal screw clamps;
- the curves in the pipe are quite wide (radius > 300 mm /11.8 inch) so as not to cause pinching or choking;
- there are no pockets or traps in the steam pipe to avoid condensation;
- the courses of the steam pipe and the condensate pipe conform to those described in this chapter;
- the length of the steam pipe does not exceed 4 metres/13.1 feet;
- the slope of the steam pipe is sufficient to drag the condensate (> 20° for the upward sections, > 5° for the downward sections);
- the slope of the condensate pipe is at least 5° at each point;
- the condensate pipe features a drain trap (filled with water before start-up) to avoid the release of steam.

9. START-UP

IMPORTANT WARNING: on completion of the installation procedure, drain the supply pipe for around 30 minutes by passing water directly through the pipe and without introducing it into the humidifier. This will allow the elimination of any scoria and processing residues that may cause the formation of foam during the boiling.

9.1 Preliminary checks

Before starting the humidifier, check that:

- the water and electrical connections are made and the steam distribution system is configured according to the instructions contained herein;
- the shut-off tap for water into the humidifier is open;
- the power fuses are installed and in tact;
- terminals 7I and 8I are connected by jumper or connected to the remote ON/OFF contact, and that the latter is closed;
- the probes or the external control device are correctly connected (and that the ground of these devices is electrically connected to the ground of the main control board);
- the steam outlet pipe is not choked;
- in the event of ducted humidification, the operation of the humidifier is slave to the operation of the air fan (replacing or in series with the remote ON/OFF contact);
- the distributor condensate return pipe is installed and free;
- the drain pipe is correctly connected and free.

! Prima dell'avviamento verificare che l'umidificatore sia in perfette condizioni, che non vi siano perdite d'acqua e che le parti elettriche siano asciutte.
Non applicare la tensione se l'apparecchio è danneggiato o anche parzialmente bagnato!

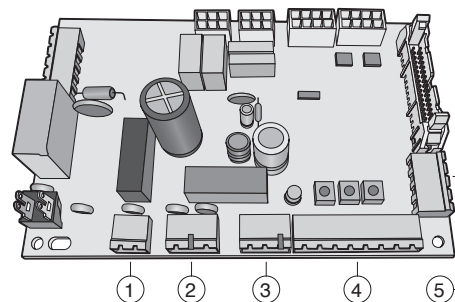

Fig. 9.a

9.2 Removing the heating element centring spring (only for three-phase models)

To prevent the elements in three-phase models hitting each other or against the internal wall of the cylinder and thus damaging the appliance, due to vibrations or bumps during transport, the heating elements are factory-fitted with a centring spring, which has no function during the operation of the appliance.

As the centring spring may hinder the removal of lime-scale from the elements and diminish the interval between cleaning cycles, the spring should be removed before the initial start-up.

To do this, remove the cylinder by following the relative instructions (see Maintenance of the cylinder-cylinder).

9.3 Start-up

After having closed the power switch to the humidifier, turn the appliance on by moving the rocker switch (next to the DRAIN button) located in the bottom right of the frame, to the I position.

The start-up sequence is then initiated. This includes the initial phase, the autotest phase, and finally, the actual operating phase.

According to the model of the humidifier's control module, the start-up sequence is signalled by the lighting up of the LEDs on the control panel, as described in the following chapter.

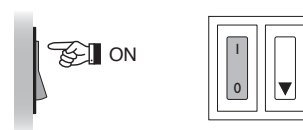

Fig. 9.b

10. THE HUMIDIFIER CONTROLLER

Two types of electronic controller are available for the electric heater humidifier (see CONTROL PRINCIPLES):

- **Type C control module, with indication LEDs and ON/OFF action**
This control provides control of the steam production capacity and ON/OFF control;
- **Type H or T control module, with numeric LED display and modulating action**
This control provides complete control of the steam production capacity, with optional dehumidification function; it accepts signals from humidity probes or from external electronic devices with proportional (or ON/OFF) control).

10.1 Type C control module, with indication LEDs and ON/OFF action

10.1.1 Front panel

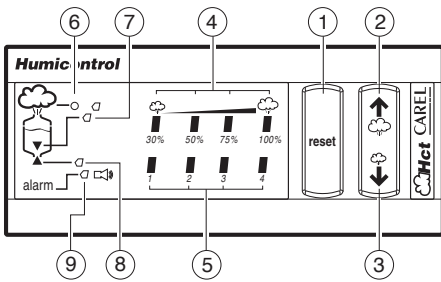

Fig. 10.a

n.	description
1	reset button for the alarm relay (if the alarm is no longer active)
2	increase programmed steam production button
3	decrease programmed steam production button
4	set steam production bar graph (percentage)
5	bar graph indicating any active alarms
6	LED indicating current steam production
7	LED indicating operation of drain electrovalve
8	LED indicating operation of the fill electrovalve
9	flashing LED indicating alarm relay activated

Table 10.a

The ON/OFF version allows the display and modification only of the steam production parameter. The other functional parameters are factory set and cannot be modified by the user (they can however be accessed via serial line).

10.1.2 Start-up sequence

On starting-up the humidifier, the start-up sequence occurs, signalled by the lighting up of the LEDs, as described below.

1 - POWER ON

In this phase, lasting around one second, all the LEDs on the display light up.

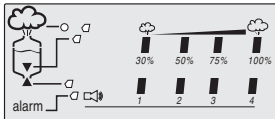

Fig. 10.b

2 - INITIALISATION

Duration around 4 seconds. The LEDs highlighted here all light up on the display.

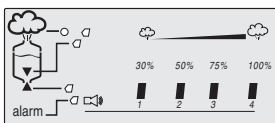

Fig. 10.c

3 - OPERATION

The humidifier, if enabled performs the autotest, and then begins operation; the control module indicates, on the four-stage bar graph (30%; 50%; 75%; 100%), the set steam production and, in the event of an alarm, the number on the corresponding bar code.

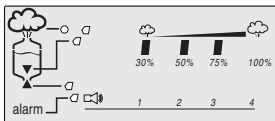

Fig. 10.d

10.1.3 Display and control

Normally the panel shows the set steam production capacity, using the 4-stage bar graph (30%; 50%; 75%; 100%).

To change the set value press the Δ and ∇ buttons. The change to the set production is stored permanently.

10.1.4 Alarm indications

The lighting up of LED 9 (see Fig. 10.a) and a combination of the LEDs 5 indicates the presence of a current alarm state; in the event of more than one alarms, the LEDs 5 light up in sequence, at 2 second intervals.

At the same time, the control module activates the alarm relay (see ELECTRICAL CONNECTIONS).

To interpret the type of alarm, see ALARMS AND TROUBLESHOOTING.

The control module continues to indicate the alarm state (even if this is no longer active) until the reset button is pressed; still active alarms can not be reset.

10.1.5 Manual drain command

In the first 5 seconds from the start-up of the unit (during the autotest sequence: see Fig. 10.c), press the Δ and ▽ buttons at the same time. After 2 seconds the drain solenoid valve is activated and completely empties the water contained in the cylinder. To stop the drain cycle, press the Δ and ▽ buttons again.

10.1.6 Setting the steam production

The average steam production can be adjusted using a pseudo-modulating action, with the cyclical activation of the remote-control switch and a programmable operating interval divided into four steps: 30%; 50%; 75%; 100% of the total time (this mode can not be applied in severe operating conditions and without consequences on the noise level caused by the frequent activation of the remote-control switch). To do this, use the Δ and ▽ buttons, see Fig. 10.a.

10.2 Type H or T control module, numeric LED display, modulating action

10.2.1 Front panel

n.	description
1	button for accessing the more frequently used functional parameters (codes Px, dx); it also acts as a reset button for the alarm relay (if the alarm is no longer active)
2	- displays the unit of measure of the value shown on the display; - pressed for 2 seconds accesses the display/programming of the set point; - if pressed together with button 1 for 5 seconds, accesses the routine for programming the configuration parameters
3	while pressed, displays the value measured by the main probe (with ON/OFF control nothing is displayed); in programming mode acts as a button to decrease the value or scroll back to the previous parameter
4	- while pressed, displays the value measured by the limit probe (only if featured); - in programming mode acts as a button to increase the value or scroll to the next parameter
5	- 2 1/2 digit display to indicate the numeric values and codes of any active alarms; - during programming shows the codes of the parameters and their values
6	LED representing the decimal point
7	LED for multiplying by one thousand the value indicated on the display
8	LED indicating the activation of the dehumidification relay
9	LED flashing indicating alarm relay activated
10	LED indicating current steam production - if flashing indicates the pre-heating phase
11	LED indicating operation of the fill electrovalve
12	LED indicating operation of the drain electrovalve

Table 10.a

10.2.2 Start-up sequence

On starting-up the humidifier, the start-up sequence occurs, signalled by the lighting up of the LEDs, as described below.

1 - POWER ON

In this phase, lasting around a second, all the LEDs on the display light up.

2 - INITIALISATION

Duration around 4 seconds. The LEDs highlighted here all light up on the display.

3 - AUTOTEST PROCEDURE

see paragraph 2.8

4 - OPERATION

The humidifier begins operation, and the control module indicates (see CONTROL PRINCIPLES) one of the following options:

- steam production (in %) with slave control;
- the measurement of the main transducer with autonomous control;
- when the humidifier is disabled, the 3 segments - - - light up in sequence.

In the event of an active alarm, the LED next to the ALARM marking lights up and the display shows the corresponding code.

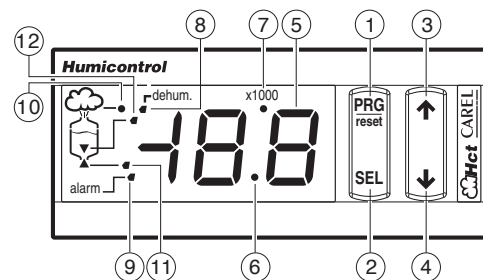

Fig. 10.e

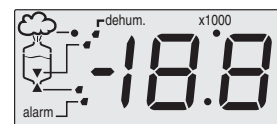

Fig. 10.f

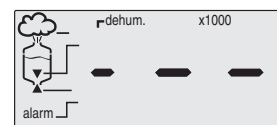

Fig. 10.g

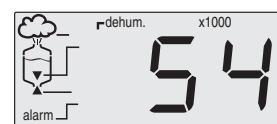
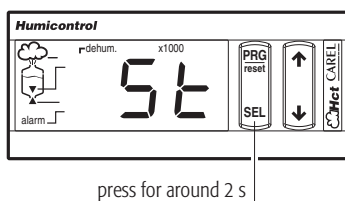

Fig. 10.h



Fgi. 10.i

10.2.3 Display

The panel shows the current functional parameter programmed (with the code C0, see Reading and programming the configuration parameters).

Normally this is:

- the measurement of probe no. 1 (ambient humidity or temperature), in appliances with autonomous control;
- steam production in appliances with slave control.

Pressing the SEL button displays for one second the unit of measure of the measurement displayed.

Pressing the Δ button shows the measurement of probe 1 (if fitted), preceded for 1 second by the corresponding unit of measure. The display is valid even in the event where the probe is not connected.

Pressing the ∇ button shows the measurement of probe 2 (if fitted), preceded for 1 second by the corresponding unit of measure. The display is valid even in the event where the probe is not connected.

To display the set point (main setting):

- press the SEL button for around 2 seconds, until St appears (see Fig. 10.i);
- on releasing the button, the unit of measure of the set point is displayed for 1 second, and finally the current set value.

Furthermore, the frequently-used functional parameters can also be displayed, that is those more commonly used by the appliance: to do this, follow the instructions in: [Reading and programming the control parameters - reading the measurements](#).

10.2.4 Changing the set point

To change the set point (main control setting), follow the instructions in: Reading and programming the set point.

10.2.5 Alarm indication

In the event of an alarm state, the LED 9 (see Fig. 10.a) starts flashing, while the display shows the alphanumeric alarm code, alternating every 2 seconds with the programmed value of the functional parameter.

If more than one alarm is indicated, the display shows all the corresponding codes in sequence, at 2 second intervals.

At the same time, the control module activates the alarm relay (see ELECTRICAL CONNECTIONS).

To interpret the type of alarm, refer to: ALARMS AND TROUBLESHOOTING. The control module will continue to indicate the alarm state (even if it is no longer active) until the reset button is pressed; still active alarm states can not be reset.

10.2.6 1. Total manual drain at SWITCH-ON

The total manual drain starts if keys Δ and ∇ are kept pressed during the initial 5 seconds after switching on heaterSteam. Once it starts, the keys can be released. The drain continues until either of the following events occurs:

- the boiler is emptied;
- keys Δ and ∇ are kept pressed again for at least 5 seconds: the drain stops.

11. READING AND PROGRAMMING THE PARAMETERS OF THE TYPE H OR T CONTROL MODULE

The numerical, configuration and control panel parameters are grouped into three levels:

- LEVEL 1 - set point**, that is the value of the appliance's main setting St, accessible directly via the keypad for both reading and modification;
- LEVEL 2 - control parameters and measurements**, that is the physical values measured and the functional parameters involving the control of the humidification process; these too can be accessed directly via the keypad for reading and modification;
- LEVEL 3 - configuration parameters** consisting of the data needed to customise the control, according to the requirements of the humidifier. These parameters are accessed only by password, to prevent the unwanted modification of the configuration and the humidifier's essential functions.

Each parameter is composed as follows:

code	alphanumeric symbol appearing on the display corresponding to the parameter in question
range of variation	limit values within which the parameter can be modified
default	value set in the factory for the parameter
unit of measure	symbol displayed showing the unit of measure used for the parameter

Table 11.a

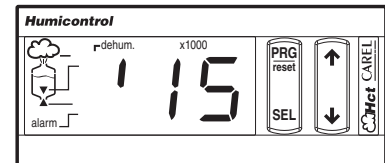

Fig. 11.a



Warning: the numerical values from 200 to 255 are displayed with the symbol / in the place of the hundreds digit 2 (due to the specific constructive configuration of the display).

Figure 11.a shows how the number 215 is displayed.

11.1 Reading and programming the set point

To read and/or change the set point, proceed as follows:

- press the SEL button for around 2 seconds, until St appears;
- on releasing the button, the unit of measure of the set point is displayed for 1 second, and finally the current set value;
- to change the set point, press the Δ and ∇ buttons, checking that the action is being performed on the display;
- press the SEL or PRG button to confirm the value displayed and conclude the programming of the set point.

The characteristics and the range of variation of the set point are listed in Table 11.b.

	unit of measure	default value	minimum limit	maximum limit
type H control module	% rH	50	0	P7
type T control module (for steam baths)	°C/°FH	30/86	0	50/122

Table 11.b

11.2 Display of SW release

The sw release is displayed any time that keys Δ and PRG are pressed together and then released.

11.3 Reading and programming the control parameters - reading the measurements

The control parameters represent the values relating to the process of ambient humidity (or temperature) control and are identified by a code ranging between P0 and P9, according to the criteria described in Table 11.c.

The readings are on the other hand the physical values measured by the transducers connected to the control, depending on the model and the setting of the humidifier, and the number of operating hours from the previous reset; the measurements are identified by a code ranging between d1 and d9 (see Table 11.d).

Control parameters

code on display	range of variation	default	unit of measure	description	
P0	10, ..,100	100	%	maximum production; in the event of modulation disabled (b0=0), the production is always at 100% of the rated value, irrespective of the value of the parameter	
P1	2.0, .., 19.9	5.0	% rH	humidification differential	can only be accessed in autonomous control (A0=2 or 3)
P2	(P3), .., 100	100	% rH	high humidity alarm threshold	
P3	0, .., (P2)	0	% rH	low humidity alarm threshold	
P4	0, .., 100	1	min	alarm delay (0*= 30 seconds)	
P5	2, .., 100	10	% rH	dehumidification dead zone	can only be accessed with dehumidification function enabled (b1=2 or 3)
P6	2.0, .., 19.9	5.0	% rH	humidification differential	
P7	(St), .., 100	100	% rH	outlet set point	can only be accessed in autonomous control with outlet probe (A0=3)
P8	2.0, .., 19.9	5.0	% rH	outlet differential	
P9	0, .., 100	100	% rH	high outlet humidity alarm threshold	

Table 11.c

list of measurements

code on display	range of variation	default	unit of measure	description	
d1 (1)	0, ..., 100	read only	%	measurement signal from external regulator	can only be accessed in slave or autonomous control (A0=1, 2 or 3)
			% rH	measurement from room probe	
d2	0, ..., 100		% rH	measurement from outlet probe	can only be accessed in autonomous control with outlet probe (A0=3)
d3	0.0, ..., 199		kg/h	steam production	
d4	0, ..., 19900		h	hour counter	
d5	0, ..., 1500		µS/cm	conductivity	
d6	0, ..., 100		°C	water temperature	can only be accessed with pre-heating function enabled (b1=1 or 3)
d9	0.0, ..., 199		kg/h	rated steam production	

Table 11.d

(1): in proportional operation (A0=1), d1 is expressed as a % of the working interval selected by A2; for information on A0 and A2: see Table 11.e.

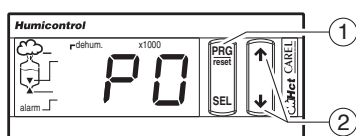

Fig. 11.c

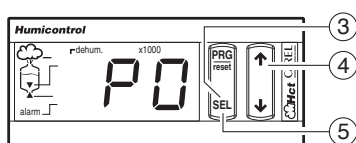

Fig. 11.d

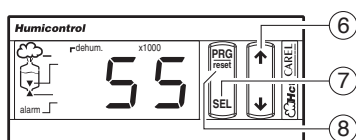

Fig. 11.e

To **display** the control parameters and the measurements, proceed as follows:

1. Press the PRG button for around 5 seconds until the code P0 appears, representing the first parameter (see Fig. 11.c);
2. Press the Δ or ∇ button to scroll cyclically through the Px and dx parameters, including the set point;
3. Press the SEL button to display the value of the selected parameter; the unit of measure of the parameter is displayed for 1 second;
4. Press the PRG button to conclude the display phase.

To **modify** the control parameters (the measurements can only be read), proceed as follows:

1. Press the PRG button for around 5 seconds until the code P0 appears, representing the first parameter (see Fig. 11.d);
2. Press the Δ or ∇ button to scroll cyclically through the Px and dx parameters, including the set point;
3. Press the SEL button to display the value of the selected parameter; the unit of measure of the parameter is displayed for 1 second;
4. Press the Δ or ∇ button to modify the value; keeping one of the buttons pressed increases the scrolling speed (see Fig. 11.e);
5. Press the SEL button to confirm the new value displayed; the identifying code Px or dx of the selected parameter will reappear;
6. Press repeatedly to scroll to next desired parameter and repeat steps 2 to 5;
7. Press the PRG button to permanently save the modifications and conclude the programming phase.

11.4 Reading and programming the configuration parameters

The configuration parameters are used to set the operating mode of the controller, that is to assign the humidifier's essential functions.

The configuration parameters are divided into three groups:

- **Parameters for configuring standard operation** (operating mode and types of probes), identified by codes from A0 to A9: see Table 11.f;
- **Parameters for configuring the operation of accessory devices**, identified by codes from b0 to b7: see Table 11.g;
- **Parameters for the setting the serial connections and remote control**, identified by codes from C0 to C7: see Table 11.i.

These parameters can be accessed only by password to prevent the unwanted modification of the configuration.

Parameters for configuring standard operation

code on display	range of variation	default	unit of measure	description	
A0	0, ..., 3	2		operating mode	0= ON/OFF command 1= slave control 2= autonomous cont. with room probe 3= autonomous cont. with room probe and outlet probe
A1	0, 1	0		unit of measure	0= °C, kg/h - 1= °F, lb/h
A2	0, ..., 4	0		signal applied to room probe input autonomous control (A0=1, 2 or 3)	0= 0/1 V - 1= 0/10 V - 2= 2/10 V - 3= 0/20 mA 4= 4/20 mA
A3	0, ..., (A4)	0	% rH	room probe minimum	can only be accessed in autonomous control (A0=2 or 3)
A4	(A3), ..., 255 *	100	% rH	room probe maximum	
A5	-10.0, ..., 10.0	0	% rH	room probe calibration	
A6	0, ..., 4	0		signal applied to the outlet probe input can only be accessed in autonomous control with outlet probe (A0=3)	0= 0/1 V - 1= 0/10 V - 2= 2/10 V - 3= 0/20 mA 4= 4/20 mA
A7	0, ..., (A8)	0	% rH	outlet probe minimum	can only be accessed in autonomous control with outlet probe (A0=3)
A8	(A7), ..., 100	100	% rH	outlet probe maximum	
A9	-10.0, ..., 10.0	0	% rH	outlet probe calibration	

Table 11.f

*: see WARNING to side of Fig. 11.a.

Parameters for configuring the operation of accessory devices

code on display	range of variation	default	unit of measure	description	
b0	0 to 199	**	s	period of modulation (if set to 0 modulation is disabled)	
b1	0 to 63	0		The user is allowed to define whether the alarm relay must be energized with or without alarm(s). This can be accomplished by setting the parameter b1 as shown in table 11.h	
b2	2 to 19.9	3.0	%	start pre-heating offset (referred to set point)	can only be accessed with pre-heating function enabled (b1=1 or 3)
			% rH		
b3	70 to 90	80	°C	pre-heating temperature	
b4	0 to 2000	0	µS/cm	supply water conductivity: if set to 0 the conductivity is measured automatically, otherwise, the set value is used	
b5	0 to 2000	1250	µS/cm	conductivity pre-alarm threshold (displayed as 1*2)	
b6	0 to 2000	1500	µS/cm	conductivity alarm threshold (displayed as 1*5)	
b7	0 to 100	50	%	control of the foam detection threshold (if set to 0 foam detection is disabled)	
b8	1 to 50	depending on the model.		maximum number of evaporation cycles between two drain cycles for dilution step:1	
b9	0 to 100	0	min	minimum time for passing from 0 to 100% of steam production	
bA	20 to 100	100	%	percentage reduction in the duration of the water fill time	
bb	-19,9 to 19,9	0	%	steam production value (step 0.1%)	allows the user to "adjust" the value displayed by parameter d3, if there is a system available for measuring the difference between the value displayed d3 and the actual steam production. Example: d3= 10 kg/h and bb= +10% changes d3 to 11 kg/h (= 10 kg/h + 10%)
bE	5 to 199	199	s	duration of the fill cycle in PWM mode	

Table 11.g

**.: il valore di default dipende dalla taglia dell'umidificatore.

Values for parameter b1

b1	preheating	dehumidification request	warning "cl"	functions		
				cumulative alarm relay energized when...	automatic total drain for inactivity	autotest
def. 0	OFF	OFF	ON	alarms present	ON	ON
1	ON	OFF	ON	alarms present	ON	ON
2	OFF	ON	ON			
3	ON	ON	ON			
4	OFF	OFF	OFF			
5	ON	OFF	OFF			
6	OFF	ON	OFF			
7	ON	ON	OFF			
8	OFF	OFF	ON			
9	ON	OFF	ON	alarms absent	ON	ON
10	OFF	ON	ON			
11	ON	ON	ON			
12	OFF	OFF	OFF			
13	ON	OFF	OFF			
14	OFF	ON	OFF			
15	ON	ON	OFF			
16	OFF	OFF	ON			
17	ON	OFF	ON	alarms present	OFF	ON
18	OFF	ON	ON			
19	ON	ON	ON			
20	OFF	OFF	OFF			
21	ON	OFF	OFF			
22	OFF	ON	OFF			
23	ON	ON	OFF			
24	OFF	OFF	ON			
25	ON	OFF	ON	alarms absent	OFF	ON
26	OFF	ON	ON			
27	ON	ON	ON			
28	OFF	OFF	OFF			
29	ON	OFF	OFF			
30	OFF	ON	OFF			
31	ON	ON	OFF			
32	OFF	OFF	ON			
33	ON	OFF	ON	alarms present	ON	OFF
34	OFF	ON	ON			
35	ON	ON	ON			
36	OFF	OFF	OFF			
37	ON	OFF	OFF			
38	OFF	ON	OFF			
39	ON	ON	OFF			
40	OFF	OFF	ON			
41	ON	OFF	ON			
42	OFF	ON	ON			
43	ON	ON	ON			
44	OFF	OFF	OFF			
45	ON	OFF	OFF			
46	OFF	ON	OFF			
47	ON	ON	OFF			

48	OFF	OFF	ON	alarms present	OFF	OFF
49	ON	OFF	ON			
50	OFF	ON	ON			
51	ON	ON	ON			
52	OFF	OFF	OFF			
53	ON	OFF	OFF			
54	OFF	ON	OFF			
55	ON	ON	OFF			
56	OFF	OFF	ON			
57	ON	OFF	ON			
58	OFF	ON	ON			
59	ON	ON	ON			
60	OFF	OFF	OFF	alarms absent	OFF	OFF
61	ON	OFF	OFF			
62	OFF	ON	OFF			
63	ON	ON	OFF			

Table 11.h

Parameters for setting the serial connections and remote control

code on display	range of variation	default	unit of measure	description	
C0	1..6	1		normally displayed value	1= room probe measurement 2= outlet probe measurement 3= steam production 4= hour counter 5= conductivity 6= water temperature
C1	0..4	4		enable keypad and remote control keypad: 0= reading of all parameters, (modification of C1 only) 1= reading and modification of all parameters 2= reading of all parameters, (modification of C1 only) 3= reading and modification of all parameters 4= reading and modification of all parameters	remote control: reading and modification of parameters P, d and St reading and modification of parameters P, d and St reading of parameters P, d and St reading of parameters P, d and St reading and modification of all parameters
C2	0..99	0		Code for enabling remote control	
C3	0..199	1		Serial address	
C4	0..3	3		baud-rate	0=1200 1=2400 2=4800 3=9600
C5	0..11	0		frame 0= 8,N,2 1= 8,N,1 2= 8,E,2 3= 8,E,1 4= 8,O,2 5= 8,O,1	(character bits, parity, stop bits) 6= 7,N,2 7= 7,N,1 8= 7,E,2 9= 7,E,1 10= 7,O,2 11= 7,O,1
C6	0..199	0	ms	serial reply send delay	
C7	0..3	0		graphic terminal configuration in cases 1,2,3 the OFF command is forced on start-up	0= standard terminal 1= terminal with ON/OFF command 2= term. with ON/OFF and room probe 3= term. with ON/OFF and outlet probe

Table 11.i

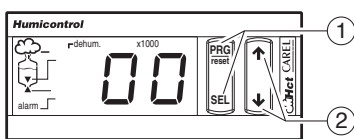

Fig. 11.j

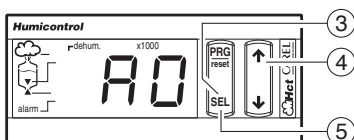

Fig. 11.k

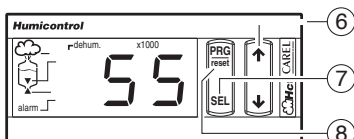

Fig. 11.l

To read or modify the configuration parameters, proceed as follows:

1. Press the SEL and PRG buttons together for around 5 seconds, until the code 00 appears, requiring the password to be entered (see Fig. 11.j);
2. Press the Δ or ∇ button until the password value is reached (number 77);
3. Press the SEL button to confirm the password. If the password is not correct, the programming phase is terminated, otherwise A0 is displayed (see Fig. 11.e);
4. Press the Δ or ∇ button to scroll cyclically through the Ax, bx and Cx parameters, including the set point;
5. Press the SEL button to display the value of the selected parameter; the unit of measure of the parameter is displayed for 1 second;
6. Press the Δ or ∇ button to modify the value (keeping one of the buttons pressed increases the scrolling speed);
7. Press the SEL button to confirm the value displayed; the identifying code Ax, bx or Cx of the selected parameter reappears;
8. Display and modify any other parameters, repeating steps 4 to 7;
9. Press the PRG button to permanently save the modifications and conclude the programming phase.

11.4 Validity of the modifications to the parameters

The modifications made to the parameters normally take effect when confirmed with the SEL button, and are saved permanently with the PRG button. For some parameters relating to the serial connection, the value will only take effect only the next time the unit is switched on. During the programming phase, 5 seconds after the last button is released, the display begins flashing (to remind the user that he is in programming phase). Sixty seconds after the last button is released, if the value of a parameter is being displayed, any modifications are ignored and the display returns to the parameter's identifying code. After a further 5 seconds, the display begins flashing again, and after 60 seconds the programming phase is terminated and the parameters return to the values previous to the programming phase. If, on the other hand, the parameter's identifying code is being displayed, the programming phase is terminated directly after 60 seconds (time out).

11.5 Recalling the default parameters (factory settings)

The default values can be recalled only on start-up, and in the following way:

- in the first 5 seconds from start-up (while the three dashes are displayed), press the PRG button until the upper dash in the centre flashes, as indicated in the Figure;
- release the PRG button within 3 seconds to confirm the recall and permanent saving of the default parameters; to confirm the saving of the values, the upper dash will stay on for 2 seconds (as displayed in Fig. 11.n);
- the operation is not effected if the PRG button is pressed for more than 3 seconds, until the upper dash disappears.

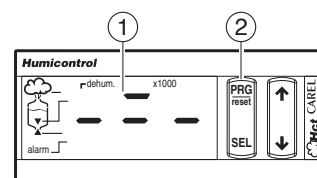

Fig. 11.n

Recalling the default parameters does not change the parameter relating to the unit of measure (A1), it is thus recommended to check and if necessary select and save the unit of measure as required, and then recall the default parameters. In this way the default values will automatically be converted.

11.6 Resetting the hour counter

To reset the hour counter (parameter d4), proceed as follows:

- press the PRG button for 5 seconds, until the code P0 is displayed, indicating the first modifiable parameter; using the Δ and ▽ buttons, scroll the parameters until d4 is displayed;
- press the SEL button to display the value of the hour counter (preceded for 1 second by the unit of measure);
- press the Δ and ▽ buttons together for 5 seconds until the value is set to zero, preceded by a brief flash.

11.7 Displaying and modifying the unit of measure

The unit of measure of some parameters depends on the type of control and the programming. Displaying the unit of measure can then avoid incorrect interpretation. In the case of non-dimensional measurements, the unit of measure is not displayed. It is also possible to use imperial rather than standard units of measure (parameter A1). For the procedure to be followed please refer to: Programming: accessing type A, b and C parameters.

The two digits on the right are used to display the unit of measure:

display	unit of measure
°C	temperature in degrees centigrade
°F	temper. in degrees Fahrenheit
rH	relative humidity in %
Pr	steam production in kg/h
Lb	steam production in pounds/h

Table 11.o

display	unit of measure
M"	time in seconds
M'	time in minutes
h	time in hours
uS	conductivity mS/cm
OO	percent

Table 11.p

11.8 Automatic total drain for inactivity

For hygienic reasons it is recommendable to empty the boiler not to have stagnant water inside in case there isn't any humidification request for a long time.

In UR*H* and UR*T* the user can set the automatic total drain for inactivity as follows (read the remarks below for UR*C*):

- The drain for inactivity is active by default. To disable it, simply go to parameter "b1" and operate as described in the table in chapter 11.4;
- Vice-versa, if the drain for inactivity has been disabled, to enable it go to parameter "b1" and operate as described in the table in chapter 11.4 and fix the maximum inactivity period through the parameter bC.

The automatic total drain for inactivity is enabled by default and the max. allowable default inactivity period is 3 days, which means that the boiler is emptied automatically after heaterSteam has been on for at least 3 days without humidification request.

Parameter bC:

Range	1 to 199 days
Default	3 days
Step	1 day
Remarks	heaterSteam must be left on in order to empty the boiler; UR*H* and UR*T*: the display shows "idr" during the automatic total drain for inactivity; UR*C*: the automatic total drain for inactivity is enabled by default and the boiler is emptied after 2 days of inactivity (fixed default) but neither b1 nor bC can be edited.

11.9 User-adjustable duration of dilution drain

The duration of the dilution drain can be adjusted through the new user parameter bD which defines the new duration as a % of the internally set default duration: new duration= default duration x bD / 100.

Example: if the internally set duration 10 s and bD= 50%, then the new duration= 10 s x 50 / 100= 5 s.

Parameter bD:

Range	0 to 190 % (0 % disables the dilution drains. WARNING: READ REMARKS BELOW!)
Default	100 %;
Step	10 %.
Remarks	bD= 0 % means that dilution drains are NOT DONE at all. WARNING: RISK OF FOAM/CORROSION as the internal conductivity will increase. We recommend to set bD= 0 after a very careful evaluation of the water quality and consequences. bD= 100 % means that the default duration will be used bD< 100 % means that the duration is < default duration: less fresh water is introduced after the drain thus reducing its negative impact on the steam production (good for high precision applications), but the drain valve will open more frequently in order to control the internal conductivity (decreasing lifetime). WARNING: RISK OF FOAM IN CASE bD IS TOO SMALL IN RELATION THE WATER QUALITY bD> 100 % means that the duration is > default duration: to be used for diluting strongly the internal water when facing big foam and/or corrosion problems. Steam flow will be negatively affected because of the larger amount of fresh water introduced after the drain; Choice of bD for a high-precision control of %rH: bD should be decreased as much as possible, yet avoiding foam/corrosion. Choice procedure: trial-and-error on field

11.10 User-adjustable max. allowed no. of evaporation cycles between 2 dilution drains

The no. of evaporation cycles between 2 subsequent dilution drains is internally calculated, but, through the new parameter b8, the user is allowed to specify the max. allowed no. of evaporation cycles between 2 dilution drains. This means that the next dilution drain is done before the end of the b8 evaporation cycle following the last dilution drain and NOT AFTER the b8-th evaporation cycle.

Parameter b8:

Range	1 to 50
Default	depends on the model
Step	1

11.11 Reduced fills to restore water level after evaporation

When, during the steam production, the upper floater switches because the water level has decreased, a fill starts for restoring the water level.

The duration of the fill can be decreased through the new user parameter bA which defines the new duration as a % of the internally set default duration: $\text{new duration} = \text{default duration} \times \text{bA} / 100$. Note that, regardless the value entered into bA, the water level will be always restored up to the upper floater.

Parameter bA:

Range	20 to 100 %
Default	100 %
Step	10 %
Remarks	<p>bA= 100 % means that the default duration will be used</p> <p>bA< 100 % means that the duration is < default duration: a smaller amount of fresh water is introduced into the cylinder, thus with a smaller impact on the steam production (good for high precision applications); on the other side, however, the fill valve will open more frequently</p>

11.12 PWM fills after dilution and high-level/foam drains

After a dilution or high-level/foam drain, water is filled into to restore the water level up to the upper floater.

The filled fresh water disturbs the steam production because it decreases the average temperature of the water inside the boiler: in order to reduce the negative influence of the fresh water on the steam production, the user can enable the PWM fills after the dilution and high-level/foam drain.

PWM fills work as follows:

1. the mass of fresh water required to restore the water level is divided into smaller masses of fresh water;
2. by keeping the partial fills as farther apart as possible from each other, each partial mass of fresh water is given the maximum possible time for heating up before the next one arrives, thus reducing the effect of the fresh water on the steam production.

The duration of each fill can be defined in seconds by the **new user parameter bE**:

Range	5 to 199 seconds
Default	seconds, which corresponds to one single fill, i.e. no PWM fills, because a 199s fill is long enough to restore alone the water level
Step	1 second

12. THE REMOTE CONTROL (OPTIONAL ACCESSORY)

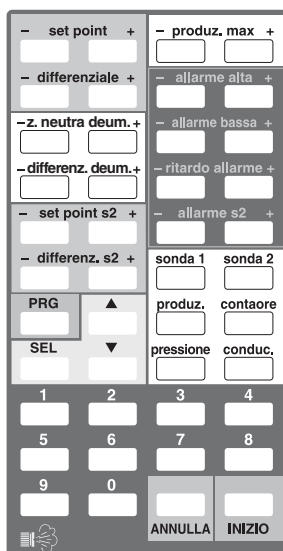

Fig. 12.a

The remote control is an optional accessory and can only be used on humidifiers with type H or T control module (modulating).

It is available in two versions:

- TELURI000 with buttons marked in Italian;
- TELURE000 with buttons marked in English.

The infra-red remote control can command the call-up and display on the control module (see THE HUMIDIFIER CONTROLLER) of the humidifier's parameters, which, if necessary, can be modified remotely. Furthermore, the remote control simplifies access to the main parameters, by pressing the corresponding marked buttons, avoiding the code search phase.

The remote control will operate at up to a distance of 3 metres, and can be used with all appliances in the heaterSteam family.

In the event where there is more than one humidifier within the remote control's operating range, the appliance to be operated can be determined by assigning each control module an individual access code (parameter C2).

Acting on the value of parameter C1 (see Reading and programming the configuration parameters) allows the parameters that can be read or modified using the remote control to be selected.

The standard value of C1 (default setting: C1=0) allows access to and modification of type P and d parameters and the set point only.

12.1 Description of the remote control

The buttons can be divided into three groups, according to their function.

12.1.1 Buttons for activating/deactivating the remote control

Allow the activation or deactivation of the remote control, saving the values associated with the parameters where necessary (see Fig. 12.b).

button	function
START	enables the use of the remote control
PRG	concludes the programming, saving the values attributed to the parameters where necessary
CANCEL	Cancels any modifications
number buttons	set the access code to the parameters



Fig. 12.b

12.1.2 Buttons for modifying the main parameters (direct access buttons)

The more-frequently used parameters are indicated directly on the remote control, grouped into areas of different colours according to the function. Each modifiable parameter has a button with the + sign and one with the - sign to increase or decrease the value.

The buttons without + or - signs only allow the display of the associated value on the control module.

12.1.3 Buttons for the remote control of the control module keypad

The section highlighted in green/blue on the remote control (see Fig. 12.c) reproduces the buttons on the instrument and allows the same operations to be performed remotely; see Reading and programming the parameters of the type H or T control module.

button	function
PRG	permanently saves the values and exits the programming phase
SEL	- displays the unit of measure and the value of the selected parameter - confirms the modified value and displays the parameter code
Δ	scrolls from one parameter to the next increases the value on the display during the setting of the parameters
∇	scrolls from one parameter to the previous decreases the value on the display during the setting of the parameters

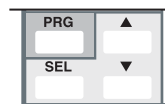

Fig. 12.c

12.2 Programming from the remote control

To activate or deactivate the access code to use the remote control, enter into the control module configuration mode using password 77 (see Reading and programming the configuration parameters).

Assigning parameter C2 a value other than 0 (from 01 to 99), activates this number as the access code that must be entered each time the remote control is used to program that unit.

Obviously, in installations with more than one unit, it is recommended to use a different code for each unit.

Setting parameter C2 back to 0 means the remote control can be used without requiring the access code.

When not in programming phase, the SEL (limited to the display of the unit of measure), PRG (limited to the function of alarm reset) and the display-only buttons are always active.

12.2.1 Enabling the control for receiving without requiring access code (C2= 0)

Exit the programming phase if necessary, press the START button to enable the remote control; the humidifier's control module will show the code for the first accessible parameter.

12.2.2 Enabling the control for receiving with access code required (C2≠ 0)

Exit the programming phase if necessary, press the START button to enable the remote control.

All the units located within the operating range of the remote control will display their own access code.

To access the programming/reading routine, use the numeric keypad (Fig. 12.b) to enter the access code for the machine to be operated on. Any zeroes must be included (e.g.: if the display shows 05, press the 0 and then the 5 button).

If the code is correct, the first accessible parameter is displayed.

12.2.3 Reading the measurements

To directly display one of the measurements featured, press the corresponding button (Fig. 12.d) twice.

12.2.4 Modifying the main parameters (with specific button)

With reference to Fig. 12.e:

- press either the + or - button corresponding to the parameter to be modified; the display shows the parameter code;
- press the SEL button again to display the value;
- then press the + or - button to increase or decrease the value.

The values in the memory of the control module will automatically be modified on exiting the programming phase.

12.2.5 Modifying the main parameters (without specific button)

The parameters without a specific button can also be modified, proceeding as follows:

- perform the operations for the enabling of the remote control;
- press the Δ or ∇ button until the code of the required parameter is displayed;
- press the SEL button to display its value; then press Δ or ∇ again to increase or decrease the value; finally, press SEL to temporarily confirm the new value;
- to modify other parameters, repeat the same operations.

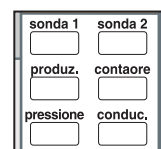

Fig. 12.d

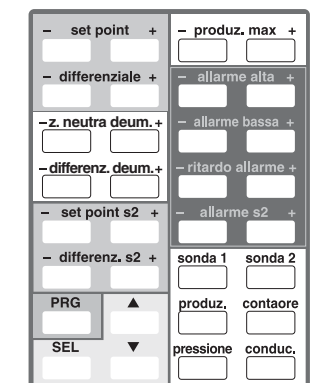

Fig. 12.e

12.3 Exiting the programming phase

To exit the programming phase and save the modifications made to the parameters, press the PRG button.

To exit without saving the modifications, press the CANCEL button.

To exit the programming phase without confirming the modifications made:

- do not press any button for 60 seconds, if the parameter code is displayed;
- do not press any button for 120 seconds, if the value of the parameter is displayed.

12.4 Table of remote control technical specifications

type	description
power supply	2 (two) 1.5V mini alkaline batteries (type UM-4 AAA, IEC R03)
case	plastic
dimensions (mm)	60 x 160 x 18
storage temperature (°C)(°fH)	-25T70 / -13T158
operating temperature (°C)(°fH)	0T40 / 32T104
type of transmission	infra-red
weight (g)(lbs)	80 / 0.17(without batteries)

Table 12.a

13. SHUTTING DOWN THE UNIT

When shutting down the unit at the end of the season or for maintenance on the electrical parts and/or plumbing, the humidifier should be put out of operation.

The water should not be emptied from the cylinder before shutting down the humidifier to avoid the hardening of the deposits contained in the cylinder and thus making them more difficult to remove.

Follow the instructions below (safety procedure):

- open the disconnecting switch on the power line to the humidifier;
- open the rocker switch in the lower right of the frame, (see Fig. 13.a) checking that the display on the control module is off;
- close the shut-off tap for the water supply to the humidifier.



Fig. 13.a

If the cylinder needs to be emptied when shutting down to remove the deposits, before switching off power to the unit, press the DRAIN rocker switch, thus forcing the drain pump electrovalve to open, keeping it in this position manually until the water is completely emptied (see Fig. 13.b).

In the event of malfunctioning of the drain pump electrovalve/ drain pump, the cylinder can be emptied manually, as following:

- humidifiers up to 10kg/h (22 lbr/h): by removing the connection pipe from the level control housing spigot and slowly draining the water into the collection base-tank of the humidifier, whereas
- humidifiers 20-27-40-60kg/h (44-59.5-88-132.2 lbr/h): by unscrewing the cap below the cylinder, (see Fig.13.b).

The cylinder can also be emptied with the appliance closed, proceeding as follows on the control panel:

- turn the unit off using the rocker switch on the lower right of the frame (see Fig. 13.a);
- turn the unit on again;
- within 5 seconds from turning the unit on, press the \uparrow and \downarrow buttons together;
- after 2 seconds the drain pump electrovalve is activated until the buttons are released; when the buttons are released, the command can be repeated within 5 seconds, otherwise the humidifier will need to be turned off and on again.

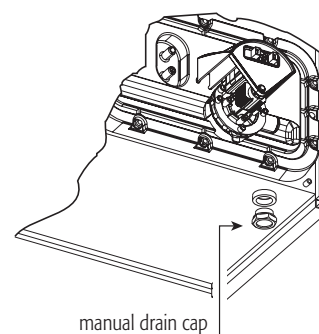

Fig. 13.b

14. MAINTENANCE

14.1 Maintenance of the cylinder-cylinder

For correct operation, the steam production cylinder must be periodically cleaned, at intervals linked to the quantity of salts or impurities dissolved in the supply water. This operation is necessary as the lime deposits that form inhibit the exchange of heat between the elements and the water.



IMPORTANT WARNING: do not use detergents or solvents to clean the components in the cylinder and all other plumbing.

The unit must be cleaned in any case when the element over-temperature alarm is activated (see ALARMS AND TROUBLESHOOTING), signalled by:

- the lighting up of LED 1 and 3, for the type C control module (see Fig. 15.a);
- the display of the message CL for the type H or T control module.

The cylinder may be hot! Let it cool before handling, or use protective gloves.

To access the cylinder:

- turn the appliance off (Fig. 13.1) and open the disconnecting switch on the power line (safety procedure);
- completely empty the water contained in the cylinder (see SHUTTING DOWN THE UNIT);
- open and remove the casing (see Removing and replacing the front casing).

The layout of the humidifier is as in Fig. 14.a.

Key:

n.	description
1	pressure balancing pipe
2	cylinder fastener closing
3	level control
4	thermal lining (optional) with Velcro fastener
5	ground connection

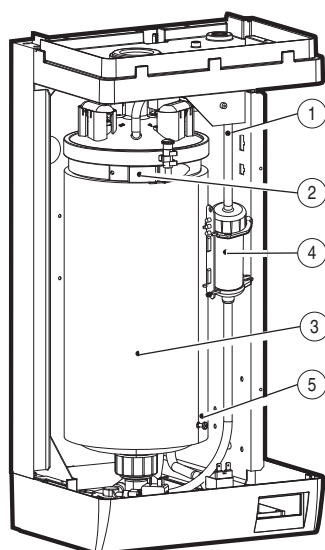

Fig. 14.a

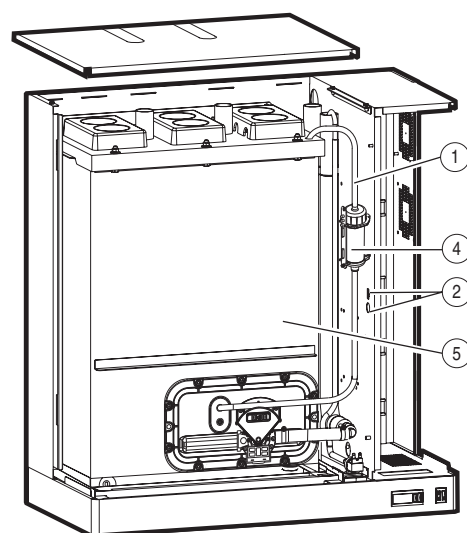

Fig. 14.b

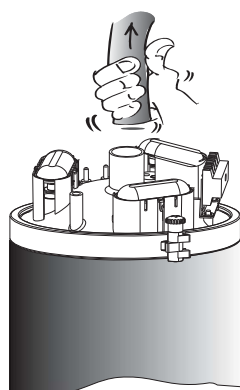

Fig. 14.c

To remove and clean the cylinder, follow the procedure as described below:

1. remove the steam pipe from the upper pipe union of the cylinder (Fig. 14.c);
2. electronically disconnect the level sensor (Fig. 14.a, part. no. 3);
3. remove, from the cylinder cover, the pressure equalising pipe with the level control tank (Fig. 14.a, part. no. 1);
4. remove the protective covers of the element electrical connections (Fig. 17.a, part. no. 5) and disconnect the power cables;
5. remove the cylinder ground screw (Fig. 14.a, part. no. 5);
6. undo the cylinder fastener by the lifting the black plastic lever (Fig. 14.a, part. no. 2) and pushing it to the end of its stroke, thus releasing the stop system;
7. lift the cylinder to remove the upper pipe union from the drain unit and remove it from the machine, paying attention to any drops of water or deposits which may be released from the pipe union;
8. if present, remove the external thermal lining (Fig. 14.a, part. no. 4);
9. place the cylinder on a working surface which is protected by a material resistant to the water and lime-scale which could be released during the cleaning operations;
10. release the cover ring fastening lever and push it to the end of its stroke (Fig. 17.a, part. no. 11); remove the metal ring, the plastic cover and its connected parts from the cylinder (see Fig. 17.a that shows the cylinder exploded view);

Cleaning of the cylinder filter 20-27-40-60 kg/h (44-59.5-88-132.2 lbr/h):

1. disconnect the pump power supply cable and the connection to the drain pipe;
2. remove from the flange the level sensor pipe;
3. unscrew the fastening screws of the flange;
4. remove the flange from the cylinder and clean the filter;

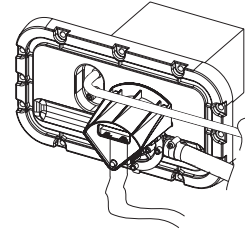

Fig. 14.d

To remove and clean the cylinder of the humidifiers from 20-27-40-60 Kg/h (44-59.5-88-132.2 lbr/h), follow the procedure as described below:

1. remove the cover of the machine (hydraulic side) unscrewing the screws (Fig. 14.b);
2. remove the steam pipe from the upper pipe union of the cylinder (Fig. 14.c);
3. electronically disconnect the level sensor (Fig. 14.a, part. no. 3);
4. remove, from the cylinder cover, the pressure equalising pipe of the level control (Fig. 14.b, part. no. 1);
5. remove the protective covers of the heating element electrical connections (Fig. 17.c part. no. 1) and disconnect the power cables;
6. remove the cylinder ground screw (Fig. 14.b, part. no. 5);
7. if present, remove the external thermal lining (Fig. 14.b, part. no. 4);
8. remove the use flange (see filter cleaning);
9. remove the cylinder making it run on the din rails;
10. place the cylinder on a working surface which is protected by a material resistant to the water and lime-scale which will be released during the cleaning operations;
11. remove the plastic cover and its connected parts from the cylinder
Before handling the elements, ensure that they are not hot! Use protective gloves if necessary.
12. Remove the non-stick film (optional), if present, from the internal wall of the cylinder, and eliminate any lime deposits from this using a jet of water (see Replacing the components
13. for humidifiers up to 10 kg/h /22 lbr/h unscrew the ring nut on the lower cylinder pipe union and remove the bottom filter, which can be reused after cleaning any deposits; the gasket can be reused or, if damaged, can be replaced and ordered as a spare part (Fig.17.a, part. no.13-14 o Fig.17.b, part 12- 13);
14. the elements can also be cleaned without removing them from the upper cover; to do this, after having removed the flaky portion of lime, immerse the heating elements in a warm 20% solution of acetic acid for 30 minutes, removing the remaining surface deposits with a non-metallic spatula, then rinse well; if the plates are Teflon-coated, avoid using any type of metal tools so as to not damage the non-stick layer;
15. if necessary, the elements can be removed by unscrewing the fastening nut which holds them to the plastic cover; in this case the seal gasket should be replaced;
16. remove the deposits and rinse the internal walls of the cylinder and the probe wells.



Re-assemble the cylinder by repeating the above operations in the reverse order, remembering to re-fasten the ground screw (Fig. 14.a e .b, part. no. 5). The procedure described above refers to the three-phase version (see Fig. 17.b).

For the power connections follow: Electrical diagram of the heating element connection corresponding to the heads.

15. ALARMS AND TROUBLESHOOTING

15.1 Alarm summary table

When an alarm is activated a message identifying the alarm is displayed on the control module. In the case of potentially dangerous alarms, the control module automatically shuts the humidifier down. For some alarm events (see Table 15.a), the signalling of the alarm is accompanied by the activation of an alarm relay, as described in: Other auxiliary contacts.

If the cause of the alarm is no longer valid, the humidifier and alarm relay output can be reset automatically or manually, according to the type of problem, while the message displayed is deactivated manually by pressing the reset-PRG button.

If no longer active, the alarm status continues to be indicated until the reset-PRG button is pressed.

Still active alarms can not be reset.

In the type C control module the presence of an alarm is indicated by the lighting up of LED 9 and a combination of the LEDs 5 (Fig. 15.a); in the event of more than one alarm, these are indicated in sequence, at 2 second intervals.

In the type H or T control module, if not in programming phase, in the presence of an alarm LED 9 (see fig. 15.b) begins flashing, while the display 5 indicates the alphanumeric alarm code.

The message is displayed cyclically, for a duration of two seconds, alternating with the measurement normally displayed (if the measurement normally displayed corresponds to a disconnected probe, the measurement is not displayed; this will automatically return to the display if the probe is reconnected). In the event of more than one alarm, the display indicates all the corresponding codes in sequence, at two second intervals.

The alarm Ec cannot be reset.

In the event of the alarm CL (regular maintenance required), the alarm can be reset only by resetting the hour counter; see **Resetting the hour counter**.

The alarm E1 may appear in two distinct cases:

- Malfunction when reading from the parameter memory** (typically on start-up)
The default parameters are temporarily recalled, without being saved in the parameter memory (the parameters can be accessed and the correct values restored). In any case the default parameter recall procedure is recommended; see **Recalling the default parameters**.
- Malfunction when writing to the parameter memory** (typically on pressing the PRG button)
Any modifications made will be cancelled; the parameters can be accessed, the values modified and save operation repeated.

Table 15.a lists the alarm indications, the causes, the conditions and the possible solutions.

The remote terminal column indicates the alarm message that appears on the LCD display of the CAREL Humivisor remote control panel, if one is connected to the humidifier.

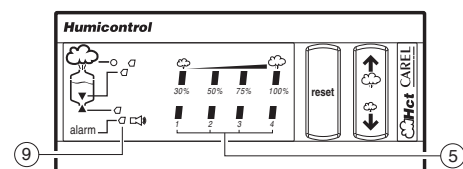

Fig. 15.a

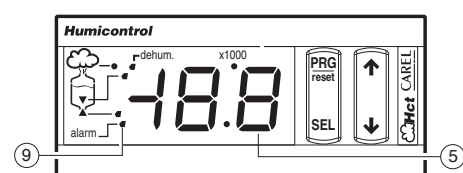

Fig. 15.b

code displayed		cause	solution (once having tried the suggestion, if the problem persists, contact the CAREL service department)	action	reset	alarm relay
H and T controller	CAREL Humivisor remote terminal					
Et		<ul style="list-style-type: none"> •activation of safety thermostat • Klixon activation •the thp output is open 	<ul style="list-style-type: none"> - check the earth current of the heaters, and if replace necessary. - manually reset the Klixon - problem dependent mainly on operation without water; - turn the machine off and, once it has cooled down,reactivate the thermostat on the cylinder cover after having cleaned the cylinder and the level control, checking the efficiency of the components; - check that the electrical and water connections are in order and that the machine is supplied correctly; - it may be necessary to replace the PTC sensors if installed 		not available	active if Et remain in order at least a minute.
EL		contradiction of the float	<ul style="list-style-type: none"> - check the correct supply of water to the cylinder; - turn the machine off and clean: the cylinder, the level control and the fill electrovalve 	see procedure "AR"	manual	only if EE appears during AR
	non previsto	high conductivity of the supply water	<ul style="list-style-type: none"> - turn the machine off and clean the water conductivity measuring electrodes; - if the problem persists, change the source of the supply water or install a suitable treatment system (demineralisation, even partial); - the problem will not be resolved by softening the supply water 	total shutdown	auto available	active





H and T controller	C controller	CAREL Humivisor remote terminal	cause	solution (once having tried the suggestion, if the problem persists, contact the CAREL service department)	action	reset	alarm relay
EE		E211	autotest failed; probable problems in: supply water, level control or electrovalve	- ensure that the machine is supplied with water; - turn the machine off and clean the level control and the fill valve	see procedure "AR"	manual	active only on the second EP or after EE during AR
		E213	• electrical power not available; on machine start-up no steam is produced or the water is not pre-heated •float locked in high level position.	with the machine off and disconnected from mains power supply, check that there are no defective or malfunctioning electrical connections	see procedure "AR"	manual	active only on the second EP or after EE during AR
		E214	no water	- check that the supply pipe from the water supply to the humidifier and the internal pipe is not blocked or choked and that the pressure is sufficient (1-8 bar); - check the operation of the fill electrovalve; - check that the steam supply does not have to work against excessive back-pressure, preventing the flow of water into the cylinder due to gravity; - check that the steam supply pipe is not choked or that there are no pockets of condensation	humidifier disabled after waiting 10 min the alarm is automatically reset and a new fill cycle is attempted	manual or automatic (if after waiting 10 min the water supply returns)	active
EA		E215	formation of foam in the cylinder during boiling	- the formation of foam is usually due to the presence of surfactants in the water (lubricants, solvents, detergents, water treatment or softening agents) or an excessive concentration of dissolved salts. Drain the water supply line; - clean the cylinder	signal only	manual	not active
Ec	not featured	E231	high water conductivity pre-alarm	- check the conductivity of the supply water; - if necessary, install a suitable water treatment system; - the problem will not be resolved by softening the supply water	humidifier disabled	auto available	not active
E-	not featured	E221	high ambient humidity (high temperature in T control)	check the operation of the probe and the limit set by parameter P2	signal only	auto available	active
/	not featured	E222	low ambient humidity low temperature in T control)	check the operation of the probe and the limit set by parameter P3	signal only	auto available	active
E=	not featured	E224	high outlet humidity	check the operation of the outlet probe	signal only	auto available	active
EO		E201	internal memory error	contact the CAREL service department	humidifier disabled	reprogram CAREL	active
E1	not featured	E212	user parameter error	with the machine off check that there are no defective or malfunctioning electrical connections	humidifier disabled	reprogram parameters	active
E2	not featured	E230	hour counter error	reset the hour counter (see Resetting the hour counter)	hour counter saving disabled	manual hour counter reset	not active
E3	not featured	E220	room probe not connected	check the connection of the probe and the setting of parameter A0 for ON/OFF configuration (see Reading and programming the parameters)	humidifier disabled	auto available	active
E4	not featured	E223	outlet probe not connected (if featured)	check the connection of the probe or the setting of parameter A0 (see Reading and programming the parameters)	humidifier disabled	auto available	active
ES	not featured	E225	NTC probe for measuring the water temperature not connected (if featured)	- check the pre-heating operation and the setting of parameters b1, b2, b3 (see Reading and programming the parameters); - check the connections to the terminal block on the cylinder cover	pre heating disabled	auto available	active
EL	not featured	E232	regular maintenance signal	stop the machine and carry out a complete maintenance routine on the humidifier, resetting the hour counter (see Resetting the hour counter)	signal only	manual	not active
Ed		E216	no drain pre-alarm or filter blocked	- check the drain valve/pump; - check if the pipes or the manifold are blocked; - check if the level sensor is faulty or the pipes are blocked; - the filter inside the boiler may be clogged.	see procedure "AR"	manual	active on the second "Ed"
EU		E233	boiler full of water with no humidification demand pre-alarm	- check if the fill valve is leaking; - check if the high level sensor is dirty.	signal only	auto available	not active

Table 15.a

15.2 Autotest Retry procedure (Fault tolerance)

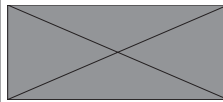
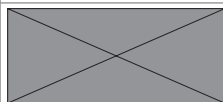
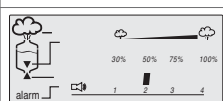
AUTOTEST RETRY ("AR")							
Step	Description	Drain status	Fill status	Contactors status	Duration	Condition that can stop "AR"	Display
1	Stop production. Open contactor	Off	Off	Off	3 sec	No	
2	Drain by time	On	Off	Off	If at the end of a set time the float is below to the minimum reed, the procedure goes to step 3, otherwise it drains again and then goes to step 3	High level sensor active	EE
3	Wait for level to stabilise	Off	Off	Off	3 sec	High level sensor active	EE
4	Fill water	Off	On	Off	Ends when the float reaches the control reed	Contradiction of the levels High level sensor active The fill time exceeds a maximum limit	EE
5	Wait for level to stabilise	Off	Off	Off	10 sec	Contradiction of the levels High level sensor	EE
6	Drain	On	Off	Off	Ends when the float reaches the control reed	Contradiction of the levels High level sensor active The drain time exceeds a maximum limit	EE
7	Wait for level to stabilise	Off	Off	Off	1 sec	Contradiction of the levels High level sensor active	EE

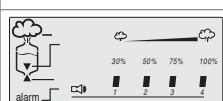
Tab. 15.b

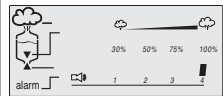
NOTE:

- During the Autotest Retry procedure the display shows the code "AR" alternating with the alarm code that triggered the procedure.
- If the PRG button is pressed during the Autotest Retry procedure, the procedure is stopped and normal humidifier operation resumes.

15.3 Troubleshooting

Problem	Cause	Solution
The control does not turn on	<ol style="list-style-type: none"> 1. no electrical power supply; 2. external switch in position 0 (open); 3. control connectors poorly installed; 4. fuses blown; 5. transformer malfunction. 	<ol style="list-style-type: none"> 1. check the protection devices upstream of the humidifier and the mains power supply; 2. close the switch: position I; 3. check that the connector are properly installed on the terminal block; 4. check the state of fuses F1/F2; 5. check that the secondary of the transformer has an output of 24 Vac.
The humidifier does not start	<ol style="list-style-type: none"> 1. remote ON/OFF contact open (relay/terminals 71 - 81); 2. the external regulator/humidistat or probe has not been connected correctly; 3. probe/humidistat malfunction; 4. parameters not set correctly; 5. safety thermostat activated; 6. fan circuit breaker activated (H or T control); 	<ol style="list-style-type: none"> 1. close ON/OFF contacts (relay/terminals 71 - 81); 2. check the external connection; 3. check the external signal; 4. reprogram the parameters correctly; 5. reset the thermostat after having eliminated the cause of the problem; 6. reset the circuit breaker after having eliminated the cause of the problem;
The humidifier fills with water without producing steam	<ol style="list-style-type: none"> 1. steam outlet back-pressure too high; 2. leaking flow regulator in the water fill electrovalve (with leaks in the water circuit); 3. level control malfunction; 4. cylinder inlet filter blocked; 5. lime in the fill tank; 6. drain electrovalve malfunction; 	<ol style="list-style-type: none"> 1. check that the steam outlet pipe is not bent or choked; 2. replace the fill electrovalve; 3. clean the level control or replace if necessary; 4. clean the filter; 5. clean the fill tank; 6. check for the presence of 24Vac at the drain electrovalve; clean the drain electrovalve;
Line circuit breaker is activated	<ol style="list-style-type: none"> 1. the line circuit breaker is rated too low; 2. resistors short-circuited 	<ol style="list-style-type: none"> 1. check that the circuit breaker is rated for a current of at least 1.5 times the rated current of the humidifier; 2. check, by measuring, the value of the resistors and replace them if necessary
The humidifier wets the duct	<ol style="list-style-type: none"> 1. the distributor is not installed correctly; 2. the system is rated too high; 3. the humidifier is active when the duct fan is off; 	<ol style="list-style-type: none"> 1. check that the steam distributor has been installed correctly; 2. diminish the steam production set on the control; 3. check the connection of the device (flow switch or differential pressure switch) linked to the humidifier for ventilation in the duct (terminals 71 - 81)
The humidifier wets the floor below	<ol style="list-style-type: none"> 1. the humidifier pipe is blocked; 2. the water supply or overflow circuit has leaks; 3. the condensate drain pipe does not drain the water back to the fill tank; 4. the steam outlet pipe is not properly attached to the cylinder; 	<ol style="list-style-type: none"> 1. clean the pipe in the bottom tank; 2. check the entire water circuit; 3. check the correct positioning of the condensate drain pipe in the fill tank; 4. check the fastening of the pipe clamp on the steam outlet pipe;

Table 15.c

16. HUMIDIFIER TECHNICAL SPECIFICATIONS

	model							
	UR002	UR004	UR006	UR010	UR020	UR027	UR040	UR060
number of heating elements	1	1	3	3	6	6	6	9
steam								
connection (φ mm)(φ inch)	30/1.18			40/1.57	40/1.57		2x40/1.57	
supply pressure limits (Pa)	0...1500				2000			
supply water								
connection	G3/4" M							
temperature limits (°C)(°fH)	1T40/33.8T104							
pressure limits (MPa)	0.1 to 0.8 (1 to 8 bar)							
hardness limits (°fH)	≤ 40							
instant flow rate (l/min) (gpm)	0,6/0.13	0,6/0.13	1,2/0.26	1,2/0.26	4/0.88	4/0.88	4/0.88	10/2.2
drain water								
connection (φ mm)(φ inch)	40/1.57							
typical temperature (°C)(°fH)	≤100 / 212							
instant flow rate (l/min)(gpm)	5/1.32				22,5/5.94			
environmental conditions								
ambient operating temperature (°C)	1T40/33.8T104							
ambient operating humidity (% rH)	10 to 60							
storage temperature (°C) (°fH)	-10T70/14T158							
storage humidity (% rH)	5 to 95							
index of protection	IP20							
control								
type	URC-URH-URS							
voltage / auxiliary frequency (V / Hz)	24 / 50/60							
maximum auxiliary power (VA)	30							
probe inputs (general characteristics)	selectable input signal: 0 to 1 Vdc, 0 to 10 Vdc, 2 to 10 Vdc, 0 to 20 mA, 4 to 20 mA							
	input impedance: 60 kΩ with signals: 0 to 1 Vdc, 0 to 10 Vdc, 2 to 10 Vdc 50 Ω with signals: 0 to 20 mA, 4 to 20 mA							
power to active probes (general characteristics)	24 Vdc (24 Vac rectified), I _{max} = 250 mA							
	12 Vdc 5%, I _{max} = 50 mA							
alarm relay and dehumidification outputs (general characteristics)	250 V 8 A (2 A) type of micro-switching action 1C							
remote enabling input (general characteristics)	free contact; max. resistance max. 50 Ω; V _{max} =24 Vdc; I _{max} =5 mA							
serial communication	two-lead RS485							

Table 16.a

17. SPARE PARTS

Exploded of the cylinder 6-10kg/h (13.2-22 lbs/h)

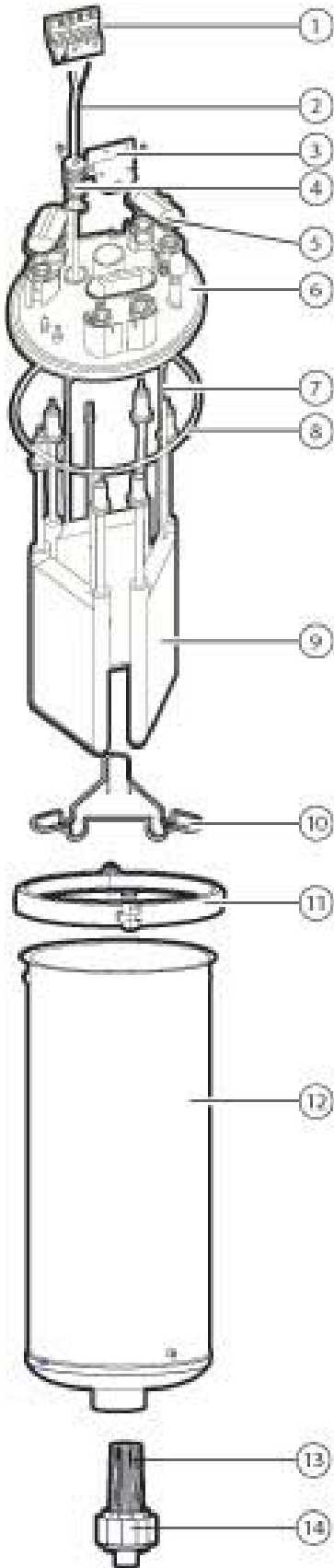

Fig. 17.a

n.	description	Spare Parts Code		
		UR006 - 1 ~ *	UR006 - 3 ~ **	UR010 - 3 ~ **
1	PTC probe wire terminals		URKTB00000	
2	NTC Probe		URKNTC0000	
3	Wire terminal bracket		URK0000022	
4	NTC well		URKNNTCCAS1	
5	Power connection protection cover		URKCOPC00M	
6	Cylinder cover			
8	Cylinder gasket		URKG100000	
11	Cylinder cover locking clamp		URKBR00000	
7	PTC probe		URKNNTCCAS1	
9	Heating elements:			
	with antiadherent film			
	208V	URKH00A347	URKH00A347	URKH00A346
	230V	URKH00A320	URKH00A320	URKH00A322
	400V		URKH00A320	URKH00A322
	460V		URKH00A344	URKH00A347
	575V		URKH00A341	URKH00A342
	without antiadherent film			
	208V	URKH00R347	URKH00R347	URKH00R346
	230V	URKH00R320	URKH00R320	URKH00R322
	400V		URKH00R320	URKH00R322
	460V		URKH00R344	URKH00R347
	575V		URKH00P341	URKH00R342
10	Heating element centring spring 13C453A048			
12	Cylinder		URKB100000	
13	Filter, ring nut and pipe union		UEKF000000	
-	Gasket kit		URKG00000M	

Table 17.a

Exploded of the cylinder 2-4 kg/h (4.4 - 8.8 lbs/h)

n.	description	Spare Parts Code		
		UR002	UR004	
1	NTC probe	URKNTC0000		
2	NTC well	URKNTCCAS2		
3	PTC probe wire terminals	URKTB00000		
4	Terminal fastening bracket	URK0000022		
5	Power connection protection cover	URKCOPC00S		
6	Cylinder cover	URKG100000		
8	Cylinder gasket			
10	Cylinder cover locking clamp			
7	PTC probe			URKPTCS000
9	Heating elements:			
	with antiadherent film	208V	URKH00A348	URKH00A349
		230V	URKH00A348	URKH00A349
	without antiadherent film	208V	URKH00R348	URKH00P349
		230V	URKH00R348	URKH00P349
11	cylinder	URKB040000		
12	filter, ring nut and pipe union	UEKF000000		
13				
-	Gasket kit	URKG00000M		

Tab.1e17.b

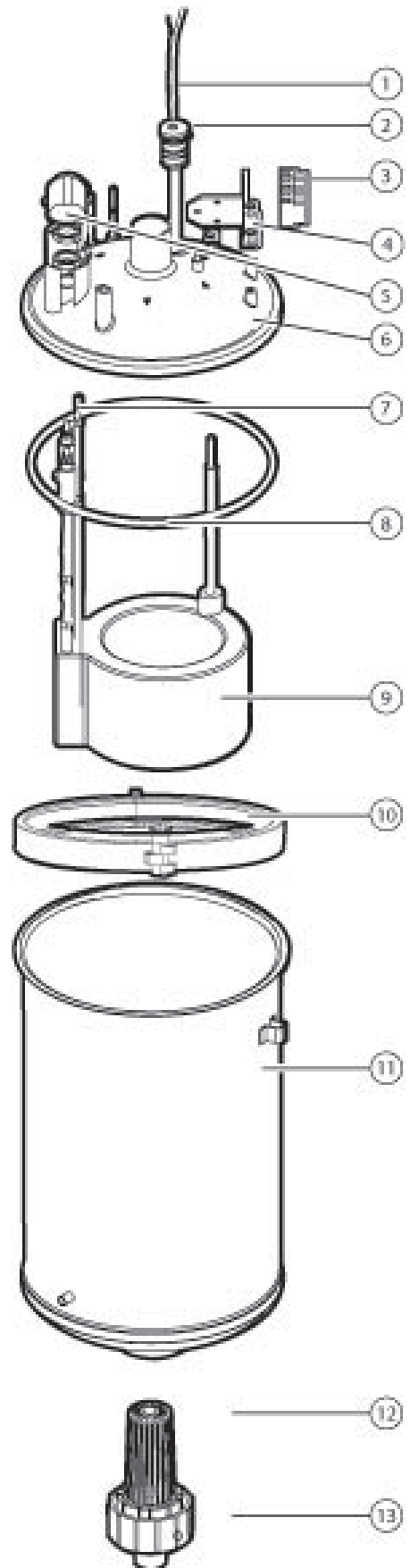

Fig. 17b

Exploded of the cylinder 20-27-40-60 kg/h 44.1-59.5-88.1-132.3 lbs/h)

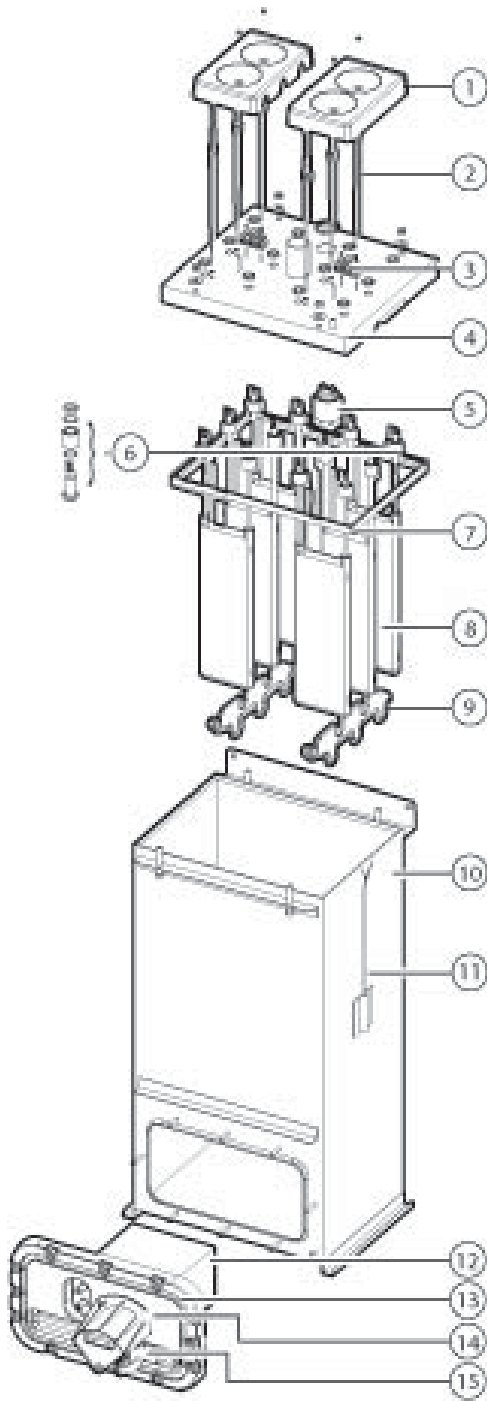

Fig. 17.c

n.	description	Spare Parts Code				
		UR020	UR027	UR040	UR060	
1	Heating element protection	---				
2	PTC probe	URKPTCL000				
3	PTC probe wire terminals	URKTB00000	URKTB00000	URKTB00000	URKTB00000	
4	Cylinder cover	URKOP4000	URKOP4000	URKOP4000	URKOP6000	
5	Anti-foaming system	URKFS00000				
6	Heating element assembly	---	--	--	--	
7	Cylinder gasket	URKG400000	URKG400000	URKG400000	URKG600000	
8	Heating element with antiadherent film	6 x	6 x	6 x	9 x	
		208V	URKH00A382	URKH00A383		
		230V	URKH00A381	URKH00A382		
		400V	URKH00A381	URKH00A382	URKH00A387	URKH00A387
		460V	URKH00A386	URKH00A381	URKH00A390	URKH00A390
	without antiadherent film	575V	URKH00A385	URKH00A380	URKH00A389	URKH00A389
		208V	URKH00R382	URKH00R383		
		230V	URKH00R381	URKH00R382		
		400V	URKH00R381	URKH00R382	URKH00R387	URKH00R387
		460V	URKH00R386	URKH00R381	URKH00R390	URKH00R390
575V	URKH00R385	URKH00R380	URKH00R389	URKH00R389		
9	Heating element centring spring	---				
10	Cylinder	URKB270000		URKB400000	URKB600000	
11	NTC probe	URKNTC0000				
12	Use filter	URKF0000XL				
13	Use flange	URKFLAN000				
14	Pump fastening braket	URKFLAN000				
15	Drain pump	KITPSR0000				
-	Gasket kit	URKG0000XL			URKG0000XXL	

Table17.c

17.a Maintenance of the other plumbing components

IMPORTANT WARNINGS: do not use detergents or solvents to clean the plastic components. To remove the deposits use a 20% acetic acid solution, then rinse thoroughly with water.

Water parts ur 2-10kg/h (4.4 - 22 lbs/h)

n.	description	Spare part codes	
		UR002 to UR004	UR006 to UR010
1	tank	UEKVASC000	
2	Supply pipe	URKT00000S	URKT00000M
3	Fill electrovalve	KITVC00006	KITVC0012
4	Level control:	URKSL00004	
4a	sensor cap		
4b	o-ring		
4c	sensor floating		
4d	sensor pipe		
4e	control board		
5	Drain electrovalve	URKDRAIN00	URKDRAIN00
6	A/D manifold (fill - drain)	URKT00000S	URKT00000M
7	Drain pipe	URKT00000S	URKT00000M
8	Overflow pipe		

Table 17.d

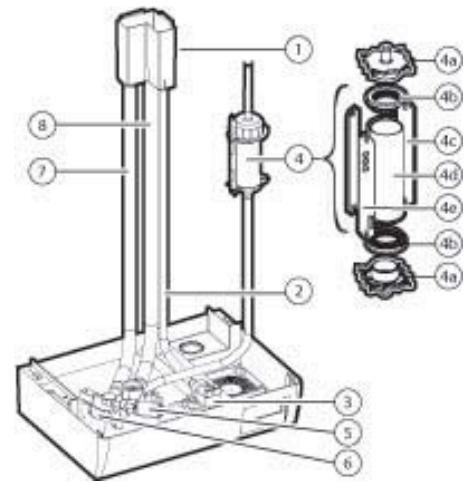

Fig. 17.d

Water parts ur 20-27-40-60 kg/h (44.1-59.5-88.1-132.3 lbs/h)

n.	description	Spare part codes			
		UR020	UR027	UR040	UR060
1	Overflow pipe	URKDC00000			
2	Drain column				
3	Supply pipe	URKT0000XL	URKT0000XL	URKT0000XL	URKT0000XL
4	Level control:	URKSL00004			
4a	Sensor cap				
4b	o-ring				
4c	sensor floating				
4d	sensor pipe				
4e	control board				
5	Drain pump	KITPS00000			
6	Fill electrovalve	KITVC00040		KITVC00100	
7	Drain tank	--	--	--	--

Table 17.e

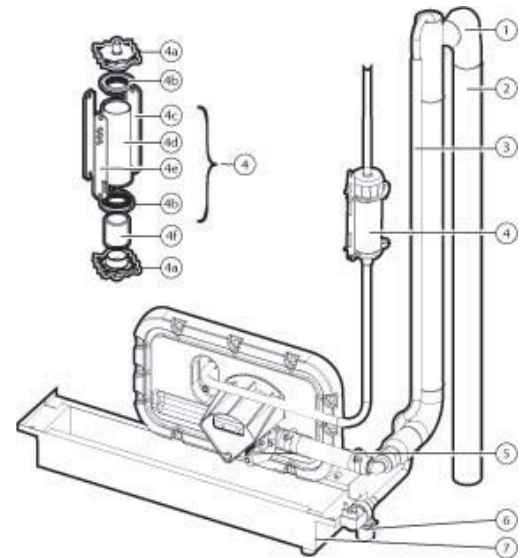

Fig. 17.e

- Fill electrovalve** (Fig. 17.d, part. no. 3 - Fig. 17.e, part. no. 6)
 After having disconnected the cables and the pipe, remove the electrovalve and check the state of the inlet filter, cleaning it if necessary using water and a soft brush.
- Supply and drain manifold** (Fig. 17.d, part. no. 6)
 Check that there are no solid residues at the cylinder coupling; remove any impurities. Check that the O-ring is not damaged or cracked; replace it if necessary.
- Drain electrovalve / drain pump** (Fig. 17.d, part. no. 5 - Fig. 17.e, part. no.5)
 Disconnect the power cables, remove the bobbin and remove the valve block after having unscrewed the two fastening screws from the manifold; remove any impurities and rinse; as regards the pump it is sufficient to screw the clamping screw and remove possible impurities;
- Fill tank** (Fig. 17.d, part. no. 1)
 Check that there are no blockages or solid particles and that the conductivity measuring electrodes are clean, remove any impurities and rinse.
- Supply, fill, overflow pipe** (Fig. 17.a, part. no.2-8 - Fig. 17.e, part. no. 3-1)
 Check that they are free and do not contain any impurities; remove any impurities and rinse.
- Level control** (Fig. 17.d, part. no.4 - Fig. 17.e, part. no. 4)
 The level control must be released from the partition wall of the cabinet. Disconnect the connector from the terminals of the electronic board, take off the connection pipes. Release the spacers and the board, then take off the caps. Check that the o-rings are not damaged or cracked; replace them if necessary. Check the cleanliness and free sliding of the two float switches. Clean all the components and reassemble and replace the device.

Carefully check that the connection pipes are properly fitted and that they are not blocked or choked at any point.



IMPORTANT WARNING: after having replaced or checked the plumbing components, check that the connections have been carried out correctly, with their corresponding seals. Re-start the machine and run through a number of fill and drain cycles (from 2 to 4), at the end of which, applying the safety procedure, check for any water leaks.

17.2 Replacing the components

17.2.1 Non-stick film

If requested as an option, the internal wall of the cylinder is lined with a non-stick film to avoid lime being deposited on the internal walls of the cylinder. To clean or replace the film, remove the cylinder following the procedure described in Maintenance of the cylinder-cylinder and then:

- slowly remove the film towards the mouth of the cylinder, without forcing it to avoid damage;
- open the film after having released the click-on couplings;
- clean the film with water and a plastic spatula if necessary; replace the film if damaged;
- wind the film around itself, reinserting the click-on couplings, and place it into the cylinder after the latter has been carefully cleaned and freed from deposits.

17.2.2 Elements

To replace the elements remove the cylinder following the procedure described in Maintenance of the cylinder-cylinder and loosen the fastening nuts from the threaded spigots of the elements. Before reassembling the elements, check the state of the gaskets and replace them if necessary.

17.2.3 PTC overtemperature sensor

The PTC sensors (one for each heating element) do not require regular maintenance; they should only be replaced if the safety thermostat is activated due to operation without water: in fact, the intervention of just one PTC will cause the control module to shut-down operation.

To replace the sensors, remove the cylinder following the procedure described in Maintenance of the cylinder-cylinder and then:

- disconnect the PTC sensor terminals (see Fig.: 7.p.a to 7.p.n);
- remove the electrical elements corresponding to the sensors being replaced;
- unscrew the PTC sensor (fig. 17.a, part. no. 7 or Fig. 17.b part. no. 7 or Fig. 17.c part. no. 2) using a spanner on the hexagonal spigot, accessible from the under side of the cover;
- reassemble a new PTC sensor, replacing the o-ring and screwing it tight; reconnect the terminals;
- reposition the electric heating elements, making sure the PTC sensor enters into the corresponding sheath in the aluminium casting.

17.2.4 NTC temperature sensor (version with type H or T control module only)

As for the PTC sensors, the NTC sensor controlling the water temperature does not require regular maintenance.

To replace this sensor, remove the cylinder following the procedure described in Maintenance of the cylinder-cylinder and then:

- disconnect the terminals of the NTC sensor (see Fig.: 7.p.a to 7.p.n);
- remove the sensor from the well housed in the measuring sheath (fig. 17.a part. no. 2, or Fig. 17.b part. no. 1, or Fig. 17.d part. no. 11);
- reposition and connect the new sensor in the place of the old one.

17.2.5 Fuses (uxiliary circuit)

These measure 10.3 x 38mm and are housed in the fuse cartridge; to check the state of the fuses, check their continuity using a tester.

Use the types of fuses indicated in table 17.e.

	models								
	UR002	UR004	UR006 - 1~*	UR006 -3~**	UR010	UR020	UR027	UR040	UR060
fuses 1 and 2 transformer power supply	All fast blow and capacity 1 A, GL, 10,3x38 contained in fuse carrier on Omega rail								
fuses 3 pump protection (on humidifiers from 20 to 60kg/h) (44.1 to 132.3 lbs/h)							1 A GL , 10,3x38 FAST		
Fuse 4 transformer secondary							2,5 A,T 5x20 in pottery		

Table 17.f

*: single-phase **: three-phase

17.2.6 Load protection fuses (humidifiers UR027 at 208-230 V, UR060 at 460 V)

Dimension of the fuses 27x60 mm rapid, housed in fuse carrier bases that can be selected. Check their continuity using a tester.

	UR027	UR060
fuses F5, F6, F7	40 A, GG	35 A, GG
fuses F8, F9, F10	40 A, GG	50 A, GG

Table 17.g

17.2.7 Solid state relays (version with type H or T control module only)

The solid-state relays (one in the single-phase unit, two in the three-phase unit) can malfunction in one of two ways: by short-circuit or burn-out. The respective consequences for the supply of power are: continuous conduction or permanent opening.

In the event of malfunctioning, check the conduction of the relay using a tester.

For the replacement of the solid-state relay:

- turn the humidifier off;
- open the disconnection switch in the power line (safety procedure);
- disconnect the power and auxiliary cables from the solid-state relay terminal block;
- remove the relay from the electrical panel by using a screwdriver to lower the fastening lever to the omega guide;
- replace the new relay on the omega guide and reconnect the wires as before.

17.2.8 Cooling fan and circuit breaker (version with type H or T control module only)

The SSR relays are cooled by a fan placed in the upper part, on the right side of the machine for the 20-60kg/h (44-132.2lbr/h) models, or placed on the base of the humidifier for the models up to 10kg/h (22lbr/h).

With insufficient ventilation the temperature of the electrical panel may rise excessively until, reaching 65°C, power to the solid-state relays is cut by a special Klixon (heat sensor, used in this application as circuit breaker - hereafter: circuit breaker), with manual reset (indicated by S2 in the wiring diagram) and without an activation signal. In this case, check:

- Whether the thermoprotective placed in the din rail near to the SSR relays has been working, or placed in front of the baffle pressing the reset button (see Fig. 17.f);
- that the fan power board, fitted in front of the baffle, is powered (input terminals: 24 Vac) and in turn powers the fan (output terminals: 24 Vdc), (only for models up to).

If the fan is faulty:

- in the models up to 10 Kg/h (22 lbs/h):
 - remove the baffle, after having unscrewed the two side nuts for fastening to the partition of the appliance;

In case of malfunction, the thermoprotective can be replaced unscrewing the fastening screws;

- in the 20-27-40-60 Kg/h (44.1-59.5-88.1-132.3 lbs/h) models:
 - unscrew the 4 fastening screws placed on the right side of the structural work and extract the fan from the inside of the panel.

In case of malfunction, the thermoprotective can be replaced removing the polycarbonate transparent protection of the solid state relays and unscrewing the fastening screws.

Key:

1	Klixon (thermoprotective - where fitted)
2	solid state relay (SSR) (where fitted)
3	fan (where fitted)
4	heatsink

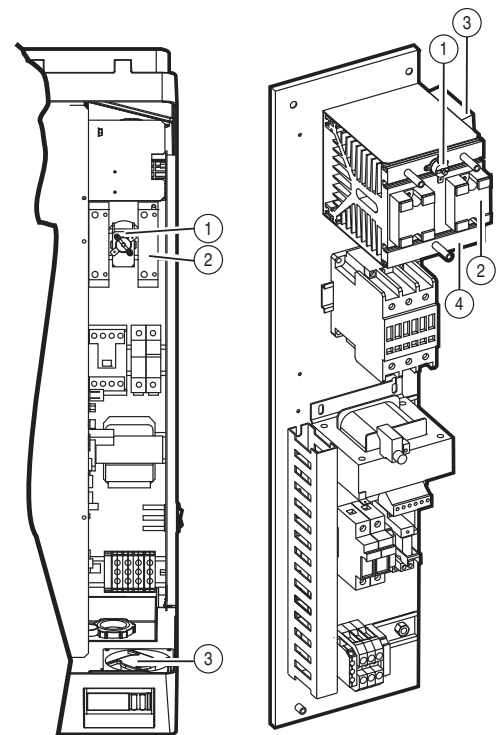

Fig. 17.f

17.3 Spare parts

Models	UR002	UR004	UR006 - 1~*	UR006 - 3~**	UR010	UR020	UR027	UR040	UR060
plumbing									
humidifier gasket kit	URKG00000M	URKG00000M	URKG00000M	URKG00000M	URKG00000M	URKG0000XL	URKG0000XL	URKG0000XL	URKG0000XL
Cylinder gasket kit	URKG100000	URKG100000	URKG100000	URKG100000	URKG100000	URKG400000	URKG400000	URKG400000	URKG600000
cylinder cover kit	URKCOPC00S	URKCOPC00S	URKCOPC00M	URKCOPC00M	URKCOPC00M	URKCOP4000	URKCOP4000	URKCOP4000	URKCOP6000
boiler cover locking bracket	URKBR00000	URKBR00000	URKBR00000	URKBR00000	URKBR00000				
cylinder filter kit	UEKF000000	UEKF000000	UEKF000000	UEKF000000	UEKF000000	URKF0000XL	URKF0000XL	URKF0000XL	URKF0000XL
						URKFLAN000	URKFLAN000	URKFLAN000	URKFLAN000
Teflon-coated heating elements									
208 V	URKH00A348	URKH00A349	URKH00A347	URKH00A347	URKH00A346	URKH00A382	URKH00A383		
230 V	URKH00A348	URKH00A349	URKH00A320	URKH00A320	URKH00A322	URKH00A381	URKH00A382		
400 V				URKH00A320	URKH00A322	URKH00A381	URKH00A382	URKH00A387	URKH00A387
460 V				URKH00A344	URKH00A347	URKH00A386	URKH00A381	URKH00A390	URKH00A390
575 V				URKH00A341	URKH00A342	URKH00A385	URKH00A380	URKH00A389	URKH00A389
non-Teflon heating elements									
208 V	URKH00R348	URKH00R349	URKH00R347	URKH00R347	URKH00R346	URKH00R382	URKH00R383		
230 V	URKH00R348	URKH00R349	URKH00R320	URKH00R320	URKH00R322	URKH00R381	URKH00R382		
400 V				URKH00R320	URKH00R322	URKH00R381	URKH00R382	URKH00R387	URKH00R387
460 V				URKH00R344	URKH00R347	URKH00R386	URKH00R381	URKH00R390	URKH00R390
575 V				URKH00R341	URKH00R342	URKH00R385	URKH00R380	URKH00R389	URKH00R389
cylinder fastening strap	URKBLOCK00	URKBLOCK00	URKBLOCK00	URKBLOCK00	URKBLOCK00	---	---	---	---
steel cylinder	URKB040000	URKB040000	URKB100000	URKB100000	URKB100000	URKB270000	URKB270000	URKB400000	URKB600000
fill tank	UEKVASC000	UEKVASC000	UEKVASC000	UEKVASC000	UEKVASC000	---	---	---	---
drain electrovalve kit	URKDRAIN00	URKDRAIN00	URKDRAIN00	URKDRAIN00	URKDRAIN00				
drain pump kit						KITPS00000	KITPS00000	KITPS00000	KITPS00000
drain pipe kit						URKT0000XL	URKT0000XL	URKT0000XL	URKT0000XL
fill valve	KITVC000006	KITVC000006	KITVC000012	KITVC000012	KITVC000012	KITVC000040	KITVC000040	KITVC000040	KITVC001000
internal pipe kit	URKT00000S	URKT00000S	URKT00000M	URKT00000M	URKT00000M	URKT0000XL	URKT0000XL	URKT0000XL	URKT0000XL
level control with sensor	URKSL00004	URKSL00004	URKSL00004	URKSL00004	URKSL00004	URKSL00004	URKSL00004	URKSL00004	URKSL00004
non-stick film	URKBAG0400	URKBAG0400	URKBAG1000	URKBAG1000	URKBAG1000	---	---	---	---
external terminal covering	URKT104000	URKT104000	URKT110000	URKT110000	URKT110000	URKT127000	URKT127000	URKT140000	URKT160000
electrical parts									
contactor									
voltage	208 V	URKCONT100	URKCONT100	URKCONT100	URKCONT100	URKCONT100	URKCONT400	URKCONT400	
	230 V							URKCONT300	
	400 V				URKCONT100	URKCONT100	URKCONT200	URKCONT200	URKCONT200
	460 V				URKCONT100	URKCONT100	URKCONT100	URKCONT200	URKCONT400
	575 V				URKCONT100	URKCONT100	URKCONT100	URKCONT200	URKCONT200
power supply transformer									
voltage	230 - 400 V	URKTR10000	URKTR10000	URKTR10000	URKTR10000	URKTR10000	URKTR40000	URKTR40000	URKTR40000
	208 - 208 - 460 - 575 V	URKTR20000	URKTR20000	URKTR20000	URKTR20000	URKTR20000	URKTR30000	URKTR30000	URKTR30000
fuse carrier									
voltage	460 V	URKFH10000	URKFH10000	URKFH10000	URKFH10000	URKFH10000	URKFH20000	URKFH20000	URKFH20000
	208-230 V						URKFH30000		URKFH30000
fuses									
F1, F2	208-230 V	URKFUSE100	URKFUSE100	URKFUSE100	URKFUSE100	URKFUSE100	URKFUSE200	URKFUSE200	
	400V				URKFUSE300	URKFUSE300	URKFUSE300	URKFUSE300	URKFUSE300
	460-575 V				URKFUSE100	URKFUSE100	URKFUSE100	URKFUSE100	URKFUSE100
F3	400V						URKFUSE300	URKFUSE300	URKFUSE300
	208-230-460-575 V						URKFUSE400	URKFUSE400	URKFUSE400
F4						URKFUSE500	URKFUSE500	URKFUSE500	
F5, F6, F7, F8, F9, F10	from 40 A (208-230V)							URKFUSE700	
F5, F6, F7	from 35 A (460V)								URKFUSE600
F8, F9, F10	from 50 A (460V)								URKFUSE800
fan									
Motor protector		URKFANS000	URKFANS000	URKFANS000	URKFANS000	URKFANS000	URKFANL000	URKFANL000	URKFANL000
		THP00A0000	THP00A0000	THP00A0000	THP00A0000	THP00A0000	THP00A0000	THP00A0000	THP00A0000
							URKKL00000	URKKL00000	URKKL00000
socket for pre-heater probe									
		URKNTCCAS2	URKNTCCAS2	URKNTCCAS1	URKNTCCAS1	URKNTCCAS1			
electronic parts									
version C control module		URCxvppri (for further information see the CAREL instruction sheet code +050003700)							
version H control module		URHxvppri (for further information see the CAREL instruction sheet code +050003700)							
version T control module		URTxvppri (for further information see the CAREL instruction sheet code +050003700)							
main control board		UR10000000	UR1000000i	UR1000000i	UR1000000i	UR1000000i	UR1000000i	UR1000000i	UR1000000i
flat connection cable		59C460A003	59C460A003	59C460A003	59C460A003	59C460A003	59C486A003	59C486A003	59C486A003
fan and SSR motorprotector		URKKL10000	URKKL10000	URKKL10000	URKKL10000	URKKL10000	URKKL10000	URKKL10000	URKKL10000
boiler motorprotector							URKKL00000	URKKL00000	URKKL00000
fan circuit breaker		6132702AXX	6132702AXX	6132702AXX	6132702AXX	6132702AXX	6132702AXX	6132702AXX	6132702AXX
fan control board		URKCFAN000	URKCFAN000	URKCFAN000	URKCFAN000	URKCFAN000			
solid state relay									
208 V	URKSSR1000	URKSSR1000	URKSSR2000	URKSSR1000	URKSSR2000	URKSSR3000	URKSSR3000		
230 V	URKSSR1000	URKSSR1000	URKSSR2000	URKSSR1000	URKSSR1000	URKSSR3000	URKSSR3000		
400 V	URKSSR1000	URKSSR1000		URKSSR1000	URKSSR1000	URKSSR3000	URKSSR3000	URKSSR3000	URKSSR3000
460 V	URKSSR1000	URKSSR1000		URKSSR1000	URKSSR1000	URKSSR3000	URKSSR3000	URKSSR3000	URKSSR3000
575 V				URKSSR1000	URKSSR1000	URKSSR3000	URKSSR3000	URKSSR3000	URKSSR3000
PTC probe (res. without antiadherent film)		URKPTCS000	URKPTCS000	URKPTCS000	URKPTCS000	URKPTCS000	URKPTCL000	URKPTCL000	URKPTCL000
NTC probe (res. with antiadherent film)		URKNTC0000	URKNTC0000	URKNTC0000	URKNTC0000	URKNTC0000	URKNTC0000	URKNTC0000	URKNTC0000

Table 17h

*: single-phase **: three-phase

17.4 Disposal of the parts of the humidifier

The humidifier is made up of metallic and plastic parts, refer to Figs. 2.a e 14.b. All these parts must be disposed of according to the local standards regarding product waste disposal.

Headquarters

CAREL S.p.A.

Via dell'Industria, 11 - 35020 Brugine - Padova (Italy)
Tel. (+39) 0499 716611 - Fax (+39) 0499 716600
carel@carel.com - www.carel.com

Subsidiaries:

CAREL Asia Ltd

Rm. 11, 8/F, Shatin Galleria,
18 Shan Mei St., Fotan, Shatin - Hong Kong
Tel. (+852) 2693 6223 - Fax: (+852) 2693 6199
e-mail: sales@carel-asia.com - www.carelhk.com

CAREL Australia Pty Ltd

PO Box 6809, Silverwater B.C. N.S.W. 1811
Unit 37, 11-21 Underwood Rd Homebush N.S.W. 2140
Tel: (+612) 8762 9200 - Fax: (+612) 9764 6933
e-mail: sales@carel.com.au - www.carel.com.au

CAREL China - CAREL Electronic (Suzhou) Co. Ltd.

No. 26, 369 Lushan Road,
Suzhou City, Jiangsu Province,
215129 P.R. of China
Tel: (+865) 12 66628098 - Fax: (+865) 12 66626631
e-mail: sales@carel-china.com - www.carel-china.com

CAREL Deutschland GmbH

Am Spielacker, 34, 63571 Gelnhausen (Germany)
Tel. (+49) 6051 96290 - Fax (+49) 6051 962924
e-mail: info@carel.de - www.carel.de

CAREL France Sas

32, rue du Champ Dolin - 69800 Saint Priest, France
Tel. (+33) 472 47 88 88 - Fax (+33) 478 90 08 08
e-mail: carelfrance@carelfrance.fr - www.carelfrance.fr

CAREL Ibérica

Automatización y control ATROL S.L.
Comte Borrell, 15 - 08015 Barcelona
Tel. (+34) 933 298 700 - Fax. (+34) 933 298 700

DELEGACIÓN CENTRO

Edificio Burgosol C/Comunidad de Madrid, 35 bis, Oficina 47
28230 Las Rozas - MADRID
tel. (+34) 91 637 59 66 - Fax: (+34) 91 637 32 07
e-mail: atrol@atrol.es - www.carel.es

CAREL Sud America Ltda

Avenida Dourado, 587 - Cep. 13.280-000 Vinhedo - São Paulo (Brasil)
Tel (+55) 19 38 26 25 65 - Fax (+55) 19 38 26 25 54
e-mail: carelsudamerica@carel.com.br - www.carel.com.br

CAREL U.K. Ltd

Unit 6, Windsor Park Industrial Estate, 50 Windsor Avenue
Merton SW19 2TJ, London (United Kingdom)
Tel. (+44) 208 545 9580 - Fax (+44) 208 543 8018
e-mail: careluk@careluk.co.uk - www.careluk.co.uk

CAREL U.S.A. L.L.C

385 South Oak Street
Manheim, PA 17545, Pennsylvania (USA)
Tel. (+1) 717-664-0500 - Fax (+1) 717-664-0449
e-mail: sales@carelusa.com - www.carelusa.com

All trademarks hereby referenced are
the property of their respective owners.
CAREL is a registered trademark of
CAREL S.p.A. in Italy and/or other countries.

© CAREL S.p.A. 2008 all rights reserved

CAREL reserves the right to modify the features of its products
without prior notice.

www.carel.com

Affiliates:

CAREL Korea Co. Ltd.

A-901, Chung Ang Circ. Complex
1258 Kuro Bon-Dong, Kuro-KU,
Seoul-KOREA
Tel: (+82) 02 2068 8001
Fax: (+82) 02 2068 8005
e-mail: info@carel.co.kr - www.carel.co.kr

CAREL Thailand Co., Ltd.

444 4th Floor OlympiaThai Building, Ratchadapisek Road,
Samsennok, Huaykwang, Bangkok 10310 Thailand
Tel: (+66) 2 513 5610
Fax: (+66) 2 513 5611
e-mail: info@carel.co.th - www.carel.co.th

CAREL Spol (Czech and Slovakia) s.r.o. Pražská 298

250 01 Brandys nad Labem, Czech Republic.
Tel: (+420) 326 377 729
Fax: (+420) 326 377 730
e-mail: carel@carel-cz.cz - www.carel-cz.cz

Agenzia / Agency: